



COPERNICUS SPACE COMPONENT SENTINEL OPTICAL IMAGING  
MISSION PERFORMANCE CLUSTER SERVICE

**Sen2Cor 2.12.03 Input-Output Data Definition**

# OPT-MPC

Copernicus Sentinel



Optical Mission Performance Cluster

Ref.: OMPC.TPZG.IOD.002  
Issue:1.0  
Date: 10/09/2024  
Contract: 4000136252/21/I-BG

|   |   |
|---|---|
| <b>Customer:</b> ESA                    | <b>Document Ref.:</b> OMPC.TPZG.IOD.002 |
| <b>Contract No.:</b> 4000136252/21/I-BG | <b>Date:</b> 10/09/2024                 |
|   | <b>Issue:</b> 1.0                       |

|                        |  |                      |  |
|------------------------|--|----------------------|--|
| <b>Project:</b>        | COPERNICUS SPACE COMPONENT SENTINEL OPTICAL IMAGING MISSION<br>PERFORMANCE CLUSTER SERVICE |                      |  |
| <b>Title:</b>          | Sen2Cor 2.12.03 Input-Output Data Definition   |                      |  |
| <b>Author(s):</b>      | Francesco C. Pignatale [Telespazio Germany GmbH]   |                      |  |
| <b>Approved by:</b>    | Jerome Louis,<br>[Telespazio France],<br>Project Manager                                   | <b>Authorized by</b> | J. Bruniquel, OPT-MPC Service<br>Manager |
| <b>Distribution:</b>   |  |                      |  |
| <b>Accepted by ESA</b> | S. Dransfeld, ESA TO   |                      | V. Boccia, ESA Deputy TO                 |
| <b>Filename</b>        | OMPC.TPZG.IOD.002 - i1r0 - Sen2Cor 2.12.03 Input Output Data Definition.docx               |                      |  |



**Copyright ©2022 – ACRI-ST**  
All rights reserved.  
*No part of this work may be disclosed to any third party translated, reproduced, copied or disseminated in any form or by any means except as defined in the contract or with the written permission of ACRI-ST*

**ACRI-ST**  
260 route du Pin Montard  
06904 Sophia-Antipolis, France  
Tel: +33 (0)4 92 96 75 00 Fax: +33 (0)4 92 96 71 17  
[www.acri-st.fr](http://www.acri-st.fr)

---

**Disclaimer**

The views expressed herein can in no way be taken to reflect the official opinion of the European Space Agency or the European Union.



### Changes Log

| Version | Date       | Changes   |
|---------|------------|---|
| 1.0.0   | 2014-03-27 | Creation  |
| 2.3.0   | 2016-11-25 | Update for Sen2Cor V.2.3.0  |
| 2.4.0   | 2017-07-18 | Update for Sen2Cor V.2.4.0  |
| 2.6.0   | 2018-02-23 | Updates for Sen2Cor V.2.6.1:<br>Updated all GIPP Schemes and description<br>Resolved RIDS from TAS.   |
| 2.7.0   | 2018-09-21 | Updates for Sen2Cor V.2.7.0: added GIPPs for Database compression factor and disabling of terrain correction with DEM. Added further command line parameters for determining database location. |
| 2.8.0   | 2019-01-29 | Updates for Sen2Cor V.2.8.0: removed parameter Nr_Processes and added parameters Nr_Treads and Ac_Dem_P2p_Val   |
| 2.9.0   | 2020-07-01 | Updates for Sen2Cor V.2.9.0: added parameters for Section Region_Of_Interest and Force_Exit_On_DEM_Errors   |
| 2.10.0  | 2021-12-13 | Updates for Sen2Cor V.2.10: updated with all the new input and output information from PSD-14.9 and Evolutionary Upgrades.  |
| 2.10.02 | 2021-04-19 | Updates mirroring changes within Sen2Cor 2.10.02  |
| 2.11.0  | 2022-11-21 | Updates mirroring changes within Sen2Cor 2.11   |
| 2.12.03 | 2024-09-10 | Updates mirroring changes within Sen2Cor 2.12   |

### List of Changes

| Version | Section | Answers to RID | Changes |
|---------|---------|----------------|---------|
|         |         |                |         |
|         |         |                |         |
|         |         |                |         |
|         |         |                |         |
|         |         |                |         |
|         |         |                |         |
|         |         |                |         |
|         |         |                |         |
|         |         |                |         |

## Table of content

|          |   |           |
|----------|---|-----------|
| <b>1</b> | <b>INTRODUCTION.....</b>  | <b>1</b>  |
| 1.1      | PURPOSE OF THE DOCUMENT .....   | 1         |
| 1.2      | DOCUMENT STRUCTURE .....  | 1         |
| 1.3      | REFERENCES .....  | 1         |
| <b>2</b> | <b>LEVEL-2A PRODUCTS OVERVIEW .....</b>   | <b>3</b>  |
| 2.1      | COMMON DATA.....  | 3         |
| 2.1.1    | <i>Input Data</i> .....   | 3         |
| 2.1.2    | <i>GIPP</i> .....   | 5         |
| 2.1.3    | <i>Metadata</i> .....   | 9         |
| 2.1.4    | <i>Auxiliary Data</i> .....   | 10        |
| 2.1.5    | <i>QI Data</i> .....  | 11        |
| 2.1.6    | <i>Output Data</i> .....  | 11        |
| 2.1.7    | <i>Command Line Parameters</i> .....  | 11        |
| 2.2      | SCENE CLASSIFICATION .....  | 12        |
| 2.2.1    | <i>Input Data</i> .....   | 12        |
| 2.2.2    | <i>GIPP</i> .....   | 12        |
| 2.2.3    | <i>Metadata</i> .....   | 13        |
| 2.2.4    | <i>Cython Library</i> .....   | 13        |
| 2.2.5    | <i>Auxiliary Data</i> .....   | 13        |
| 2.2.6    | <i>Output Data</i> .....  | 16        |
| 2.3      | ATMOSPHERIC CORRECTION .....  | 18        |
| 2.3.1    | <i>Input Data</i> .....   | 18        |
| 2.3.2    | <i>GIPP</i> .....   | 18        |
| 2.3.3    | <i>Metadata</i> .....   | 21        |
| 2.3.4    | <i>Auxiliary Data (Look Up Tables)</i> .....  | 21        |
| 2.3.5    | <i>Output Data</i> .....  | 23        |
| 2.3.6    | <i>Aerosol Optical Thickness Retrieval</i> .....                                      | 23        |
| 2.3.7    | <i>Water Vapour Retrieval</i> .....   | 25        |
| 2.3.8    | <i>Cirrus Correction</i> .....  | 27        |
| 2.3.9    | <i>Terrain Correction</i> .....   | 27        |
| 2.3.10   | <i>Surface Reflectance (Hemispherical-directional reflectance factor, HDRF)</i> ..... | 29        |
| 2.4      | QUALITY MASK .....  | 33        |
| 2.4.1    | <i>Input Data</i> .....   | 33        |
| 2.4.2    | <i>GIPP</i> .....   | 33        |
| 2.4.3    | <i>Metadata</i> .....   | 33        |
| 2.4.4    | <i>Output Data</i> .....  | 33        |
| 2.5      | PRODUCT GENERATION .....  | 33        |
| 2.5.1    | <i>Input Data</i> .....   | 33        |
| 2.5.2    | <i>Output Data</i> .....  | 34        |
| <b>3</b> | <b>GIPP ADDITIONAL SETTINGS .....</b>   | <b>39</b> |



3.1 EXPERT PARAMETERS FOR SCENE CLASSIFICATION ..... 39

3.2 EXPERT PARAMETERS FOR ATMOSPHERIC CORRECTION ..... 39

3.3 PROCESSING BASELINE PARAMETERS ..... 40

3.4 ADDITIONAL DOCUMENTATION ..... 41

## List of Figures

|   |    |
|---|----|
| Figure 1 – GIPP of Common Section -----                     | 6  |
| Figure 2 – GIPP of Scene Classification -----               | 12 |
| Figure 3 – QI Data of Tile and User Product Metadata -----  | 16 |
| Figure 4 – GIPP for Atmospheric Correction Module -----     | 19 |
| Figure 5 – GIPP for selection of Look_Up_Tables -----       | 24 |
| Figure 6 – General schema of the new L2A_Quality file ----- | 35 |
| Figure 7 – Processing Baseline GIPP -----                   | 39 |
| Figure 8 – Processing Baseline GIPP -----                   | 40 |
| Figure 9 – Processing Baseline GIPP -----                   | 40 |

## List of Tables

|  |    |
|--|----|
| Table 2-1 – L1C Image data specification -----                       | 3  |
| Table 2-2 – Common GIPP -----  | 7  |
| Table 2-3 – Metadata input fields (see L2A-PFS for details) -----    | 10 |
| Table 2-4 – Aux_Data -----   | 10 |
| Table 2-5 – QI_Data -----  | 11 |
| Table 2-6 – Command Line Parameters -----                            | 11 |
| Table 2-7 – GIPP of Scene Classification -----                       | 13 |
| Table 2-8 – Cloud Probability map -----                              | 17 |
| Table 2-9 – Snow Probability map -----                               | 17 |
| Table 2-10 – Scene Classification -----                              | 17 |
| Table 2-11 – GIPP for selection of Look_Up_Tables -----              | 19 |
| Table 2-12 – Parameter space for atmospheric correction -----        | 21 |
| Table 2-13 – LUT file naming conventions -----                       | 21 |
| Table 2-14 – Structure and format of the atmospheric LUT files ----- | 22 |
| Table 2-15 – Column structure of atmospheric LUT files -----         | 23 |
| Table 2-16 – Band subsets -----                                      | 24 |
| Table 2-17 – CAMS auxiliary input -----                              | 24 |
| Table 2-18 – Aerosol Optical Thickness (AOT) map -----               | 25 |
| Table 2-19 – WVP columns -----                                       | 25 |
| Table 2-20 – Band subsets -----                                      | 26 |
| Table 2-21 – GIPP input fields -----                                 | 26 |
| Table 2-22 – Water Vapour Map -----                                  | 26 |
| Table 2-23 – Band subset -----                                       | 27 |
| Table 2-24 – Inputs parameter cirrus correction -----                | 27 |
| Table 2-25 – GIPP terrain correction -----                           | 28 |
| Table 2-26 – GIPP surface reflectance -----                          | 29 |
| Table 2-27 – Outputs surface reflectance -----                       | 30 |
| Table 3-1 – Processing Baseline GIPP -----                           | 41 |

|   |  |   |
|---|--|---|
|  | <p><b>Optical MPC</b></p> <p><b>Sen2Cor 2.12.03 Input-Output Data Definition</b></p> | <p>Ref.: OMPC.TPZG.IOD.002</p> <p>Issue: 1.0</p> <p>Date: 10/09/2024</p> <p>Page: 1</p> |
|---|--|---|

# 1 Introduction

## 1.1 Purpose of the document

This Document lists the Input-Output Data Definitions of the Sen2Cor application. This Document is updated with the corrective, perfective maintenance and evolutions present in the latest Sen2Cor 2.12.03 version [OMPC-TPZG-SRN].

## 1.2 Document Structure

This document includes new dedicated sections with all the input and output related to the evolutions implemented since Sen2Cor 2.10 and updates for **2.12.03** where present. Furthermore, this document lists for each of the following processes:

- ❖ Scene Classification;
- ❖ Atmospheric Correction, with sub-processes:
  - Aerosol Optical Thickness (AOT) retrieval;
  - Water Vapour retrieval;
  - Cirrus Correction;
  - Terrain Correction;
  - Surface Reflectance (Hemispherical-directional reflectance factor, HDRF);
- ❖ Quality Masks;

the corresponding Input and Output (I/O) data separated according the following four criteria (when applicable):

- ❖ Input Data;
- ❖ Ground Image Processing Parameter (GIPP);
- ❖ Metadata;
- ❖ Output Data.

## 1.3 References

| Document ID         | Description  | Version        |
|---------------------|--|----------------|
| S2-PDGS-MPC-L2A-PFS | Sentinel-2 MSI – Product Format Specification                                    | 14.6,14.9,15.0 |
| S2-PDGS-MPC-L2A-PFS | Sentinel-2 MSI – Product Format Specification                                    | 14.9           |
| OMPC-TPZG-SUM       | Sentinel-2 MSI – Level 2A Prototype Processor Installation and User Manual (002) | 2.12           |
| OMPC-TPZG-SRN       | Sentinel-2 MSI – Level 2A Prototype Processor Software Release Note (006)        | 2.12           |





| Document ID          | Description   | Version  |
|----------------------|---|----------|
| S2-PDGS-MPC-L2A-ATBD | Sentinel-2 MSI - Level 2A Products, Algorithm Theoretical Basis Document                          | 2.10     |
| S2-PDD               | GMES Space Component – Sentinel-2 Payload Data Ground Segment (PDGS), Product Definition Document | 14.9_4.9 |
| S2-PSD               | Sentinel-2 Products Specification Document  | 14.6     |
| S2-PSD               | Sentinel-2 Products Specification Document  | 14.9     |
| S2-PSD_15            | Sentinel-2 Products Specification Document  | 15.0     |

## 2 Level-2A Products Overview

### 2.1 Common Data

This section lists I/O data and parameters that are related to the basic operation of the processor.

#### 2.1.1 Input Data

The input data on pixel level and the L1C product formats are described in detail in [L2A-PFS], see also Table 2-1.

**Table 2-1 – L1C Image data specification**

| Name                  | Level-1C   |
|-----------------------|--|
| Parent Product        | L1C, TOA Reflectance                                   |
| Coverage              | Regional. 110 km x 110 km                              |
| Packaging             | MGRS Tiles (same area coverage as Level 1C input data) |
| Geo-location accuracy | Identical to the level 1C geo-location performance     |
| Frequency             | 5 days repeat cycle with two Sentinel-2 satellites     |

| Name   | Level-1C   |
|--------|--|
| Format | <p>Kakadu 7.4, details @60 m processing:</p> <p>Codestream, import Band1, 60m res:</p> <p>SOC marker segment @ (1927, 0)</p> <p>SIZ marker segment @ (1929, 41)</p> <p>Profile: no profile</p> <p>Reference Grid Height, Width: (1830 x 1830)</p> <p>Vertical, Horizontal Reference Grid Offset: (0 x 0)</p> <p>Reference Tile Height, Width: (192 x 192)</p> <p>Vertical, Horizontal Reference Tile Offset: (0 x 0)</p> <p>Bitdepth: (15,)</p> <p>Signed: (False,)</p> <p>Vertical, Horizontal Subsampling: ((1, 1),)</p> <p>COD marker segment @ (1972, 17)</p> <p>Coding style:</p> <p>Entropy coder, with partitions</p> <p>SOP marker segments: False</p> <p>EPH marker segments: False</p> <p>Coding style parameters:</p> <p>Progression order: LRCP</p> <p>Number of layers: 1</p> <p>Multiple component transformation usage: no transform specified</p> <p>Number of resolutions: 5</p> <p>Code block height, width: (4 x 4)</p> <p>Wavelet transform: 5-3 reversible</p> <p>Precinct size: ((64, 64),(64, 64),(64, 64),(64, 64),(64, 64))</p> <p>Code block context:</p> <p>Selective arithmetic coding bypass: False</p> <p>Reset context probabilities on coding pass boundaries: False</p> <p>Termination on each coding pass: False</p> <p>Vertically stripe causal context: False</p> <p>Predictable termination: False</p> <p>Segmentation symbols: False</p> <p>QCD marker segment @ (1991, 16)</p> <p>Quantization style: no quantization, 1 guard bits</p> <p>Step size: [(0, 16), (0, 17), (0, 17), (0, 18), (0, 17), (0, 17), (0, 18), (0, 17), (0, 17), (0, 17), (0, 16), (0, 16), (0, 17)]</p> <p>CME marker segment @ (2009, 15)</p> <p>"Kakadu-v7.4"</p> <p>CME marker segment @ (2026, 92)</p> <p>"Kdu-Layer-Info: log<sub>2</sub>{Delta-D(squared-error)/Delta-L(bytes)},</p> <p>L(bytes) -192.0, 3.8e+06"</p> |
| Unit   | Dimensionless, Unsigned Integer 15 bit   |

| Name                    | Level-1C  |
|-------------------------|---|
| Calibration and Range   | Quantification value: 10000<br>Radiometric offset: 1000<br>i.e.: Digital Numbers [1000 , 11000], representing radiometric reflectance values from 0.0 to 1.0<br>Reflectance = (DN – 1000) / 10000 |
| Sampling                | 16 bit/pixel  |
| Channels and Resolution | Resolution (m)  |
| B1 (443nm)              | 60  |
| B2 (490nm)              | 10  |
| B3 (560nm)              | 10  |
| B4 (665nm)              | 10  |
| B5 (705nm)              | 20  |
| B6 (740nm)              | 20  |
| B7 (783nm)              | 20  |
| B8 (842nm)              | 10  |
| B8a (865nm)             | 20  |
| B9 (945nm)              | 60  |
| B10 (1375)              | 60  |
| B11 (1610nm)            | 20  |
| B12 (2190nm)            | 20  |

### 2.1.2 GIPP

GIPPs are configured in an XML file named `L2A_GIPP.xml`, located in the `<cfg>` subdirectory of the Sen2Cor home directory which is specified by the environment variable `$SEN2COR_HOME`, and can be configured by the user. Exceptions, which should not be configured by standard users, are marked with an asterisk (\*).

The file is subsequently copied into the `AUX_DATA` subfolder of the corresponding granule for documentation purposes.

Within this IODD the GIPP are listed within their current processing context. Figure 1 and Table 2-2 show and describe the GIPP, which are common for the overall processing. Specific GIPPs are listed in the corresponding subsections separated for each sub-processing step.

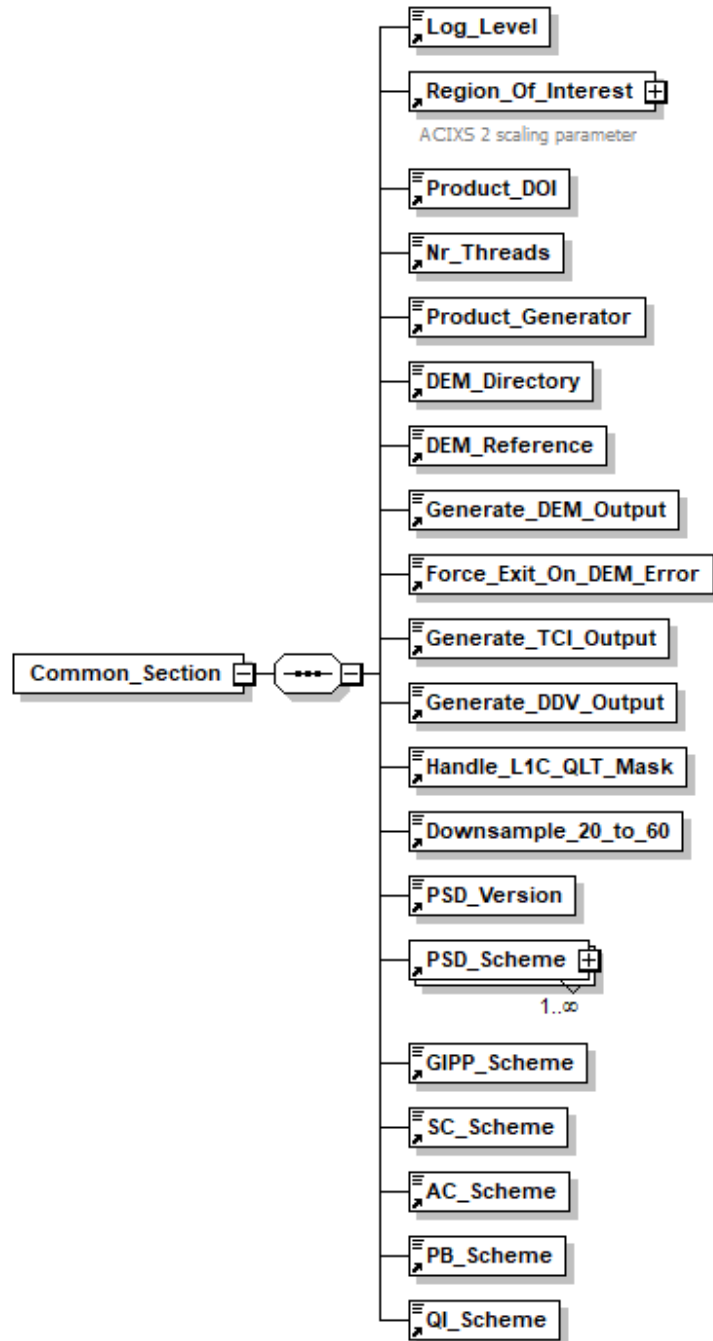

Generated by XMLSpy

www.altova.com

Figure 1 – GIPP of Common Section

Table 2-2 – Common GIPP

| Field Name                             | Documentation   | Type   |
|--|---|--|
| Log_Level(*)                           | Verbosity level of the tracing output, located in the GRANULE/<GRANULE>/QI_DATA folder.   | Enumerator:<br>NOTSET, DEBUG, INFO, WARNING, ERROR, CRITICAL   |
| Region_Of_Interest                     | <p>This section has been established with release 2.9.0. It contains four parameters which define a configurable Region of Interest (ROI):</p> <ul style="list-style-type: none"> <li>row0</li> <li>col0</li> <li>nrow_win</li> <li>ncol_win</li> </ul> <p>row0, col0, nrow_win and ncol_win must be integer divisible by 6, to prevent rounding errors for downsampling. See SUM for Details.</p>                | <p>Choice:<br/>Off, AUTO or:<br/>Unsigned Integer Values [0:10979]<br/>if row0 == OFF: a standard processing without ROI detection is performed;<br/>if row0 == AUTO: a region of interest is detected automatically via an algorithm;<br/>Else:<br/>row0, col0: specify the midpoint of the region of interest, nrow_win, ncol_win define a rectangle around the midpoint within a frame of 10980 x 10980 pixel</p> |
| Product DOI (Since Sen2Cor 2.10)       | DOI: Digital Object Identifier. This Object identifier is implemented since Sen2Cor 2.10 for PSD Versions 14.7 and above. The URL shall be inserted as a configuration item in this entry (The official URL is provided by ESA)   | URL  |
| Nr_Threads                             | This parameter allowing the usage of multithreading to speed up the reading of the L1C input images. above). It is set to AUTO by default, which detects the amount of usable threads by calling cpu_count(). If the user does not want this feature or want to set the number of threads individually, the parameter can be changed between a value of 1 (which is single thread processing, as before) up to 8. | Choice:<br>AUTO or:<br>Unsigned Integer Value [1:8]  |
| Product Generator (Since Sen2Cor 2.10) | This parameter foresees the usage of the PDGS PSD converter in the toolbox mode.<br>Not yet implemented.  | Choice:<br>Directory where the converter is located or 'NONE'  |

| Field Name                                  | Documentation  | Type  |
|---|--|---|
| DEM_Directory                               | Location of optional Digital Elevation Map: can be either a directory in the sen2cor home folder or 'NONE'. If NONE, no DEM will be used.<br><br>Example: 'dem/srtm'. DEM will be searched in:<br><SEN2COR_HOME>/dem/srtm  | Choice:<br>NONE or String (relative directory path) |
| DEM_Reference                               | If no suitable DEM is found in the DEM directory, the processor tries to download a DEM from the given reference.<br><br>-Copernicus DEM<br>Since its version 2.12.01, Sen2Cor support the download of Copernicus DEM from the Amazon Web Service. Please Refer to the [OMPC-TPZG-SUM].<br><br>-SRTM<br>the freely available CGIAR 90 m resolution DEM, which can be downloaded following:<br><a href="http://data_public:GDdci@data.cgiar-csi.org/srtm/tiles/GeoTIFF">http://data_public:GDdci@data.cgiar-csi.org/srtm/tiles/GeoTIFF</a><br><a href="https://srtm.csi.cgiar.org/disclaimer/">https://srtm.csi.cgiar.org/disclaimer/</a> | URL/STRING  |
| Generate_DEM_Output                         | FALSE: no DEM output, TRUE: store DEM in the AUX data directory  | FALSE or TRUE                                       |
| Force_Exit_On_DEM_Error                     | This parameter has been established with release 2.9.0: if set to FALSE, processing continues with a flat surface, if a DEM is not found or cannot be downloaded. If set to TRUE, processing will be stopped.  | FALSE or TRUE                                       |
| Generate_TCI_Output                         | FALSE: no TCI output, TRUE: store TCI in the IMAGE data directory  | FALSE or TRUE                                       |
| Generate_DDV_Output                         | FALSE: no DDV output, TRUE: store DDV in the QI_DATA directory   | FALSE or TRUE                                       |
| Handle_L1C_QLT_Mask<br>(Since Sen2Cor 2.10) | FALSE: no handling of the L1C Quality Mask. TRUE: handling L1C Quality Mask  | FALSE or TRUE                                       |
| Downsample_20_to_60                         | TRUE: create additional 60m bands when 20m is processed  | FALSE or TRUE                                       |
| PSD_Version<br>(Sen2Cor 2.10.01 and up)     | Special entry for forcing a special PSD version to be processed. DEFAULT: automatic detection of the PSD version.  | DEFAULT or PSD version                              |

| Field Name                        | Documentation  | Type   |
|-----------------------------------|--|--|
| PSD_Scheme (*)                    | <p>List of supported PSD Versions:<br/> V 14.2 – V.14.6 (since Sen2Cor 2.9.0)<br/> V 14.9 (since Sen2Cor 2.10)<br/> V 15.0 (since Sen2Cor 2.12.01)</p> <p><u>Properties:</u></p> <ul style="list-style-type: none"> <li>Version: The PSD Versions</li> <li>PSD_Reference: the names of the available PSD schemes</li> </ul> <p><u>Names:</u><br/> UP_Scheme_1C: &lt;name&gt;<br/> UP_Scheme_2A: &lt;name&gt;<br/> Tile_Scheme_1C &lt;name&gt;<br/> Tile_Scheme_2A &lt;name&gt;<br/> DS_Scheme_1C: &lt;name&gt;<br/> DS_Scheme_2A: &lt;name&gt;</p> <p><u>Remark:</u> these schemes are used for validation of the in- and output metadata. The configuration should not be changed by the user</p> | XML List of strings                            |
| GIPP_Scheme (*)                   | Name of the xsd scheme for the base GIPP (this file, used for validation purposes)   | String (filename). Default is L2A_GIPP         |
| SC_Scheme (*)                     | Name of the xsd scheme for the expert calibration GIPP for scene classification (used for validation purposes, not foreseen to be configured by standard uses).  | String (filename). Default is: L2A_CAL_SC_GIPP |
| AC_Scheme (*)                     | Name of the xsd scheme for the expert calibration GIPP for the atmospheric correction (used for validation purposes, not foreseen to be configured by standard uses).  | String (filename). Default is:L2A_CAL_AC_GIPP  |
| PB_Scheme (*)                     | Name of the xsd scheme for the Processing Baseline.  | String (filename). Default is:L2A_PB-_GIPP     |
| QI_Scheme(*)<br>(Sen2Cor 2.10.01) | Name of the xsd scheme for the L2A_Quality report  | String (filename). Default is: L2A_QUALITY     |

For a full list of all types, parameters, and default values, please consult the embedded PDF in the 3.4.

### 2.1.3 Metadata

Metadata (Table 2-3) are read out directly from the Level 2A Tile metadata XML file after being generated from the corresponding Level-1C User product.



**Table 2-3 – Metadata input fields (see L2A-PFS for details)**

| Field Name                                      | Documentation  | Type                        |
|---|--|-----------------------------|
| ZENITH_ANGLE                                    | Incidence angles   | Floating point 32 bit       |
| AZIMUTH_ANGLE                                   | Incidence angles   | Floating point 32 bit       |
| Zenith  | Grids for Zenith Viewing Incidence Angle values (0 - 70°)                                      | Floating point array 32 bit |
| Azimuth   | Grids for Azimuth Viewing Incidence Angle values (0 – 360°)                                    | Floating point array 32 bit |
| QUANTIFICATION_VALUE                            | Digital Number of L1C Input bands, dimensionless, 0 :10.000 corresponds to TOA reflectance 0:1 | Unsigned Integer            |
| ECMWF_DATA_REFERENCE                            | Filename of the ECMWF data located in the GRANULE/AUX_DATA folder                              | String (filename)           |
| Radiometric_Offset_List<br>(since Sen2Cor 2.10) | List of band dependent radiometric offset  | Integer                     |

### 2.1.4 Auxiliary Data

**Table 2-4 – Aux\_Data**

| Field Name | Documentation   | Type  |
|------------|---|---|
| DEM        | Digital Elevation Map, user configurable image data located in \$SEN2COR_HOME, directory, configurable via L2A_GIPP, see Table 2 – Common GIPP<br>Unit: m | In output of Sen2Cor, as OpenJPEG is only able to store unsigned integer values, an offset of +10.000 is applied to each DEM allowing for negative heights. The scale of the DEM is thus (meter – 10.000).<br>Integer, 16 bit |

| Field Name  | Documentation  | Type     |
|---|--|----------|
| AUX_ECMWF, located in the GRANULE/AUX_DATA folder | Raster data of Block Size 9:9 in GRIB Format, 6 Bands, specifying:<br>B1: Precipitable water content [kg/m <sup>2</sup> ]<br>B2: Mean sea level pressure [Pa]<br>B3: Total column ozone Dobson [kg/m <sup>2</sup> ]<br>B4: 10m U wind component [m/s]<br>B5: 10m V wind component [m/s]<br>B6: Relative humidity [%] | Float 64 |
| AUX_CAMSxx<br>(Since Sen2Cor 2.10)                | Raster data of Block Size 9:9 in GRIB Format, 11 bands of which the following are used:<br>-Total Aerosol Optical Depth at 550nm (aod550);<br>- Surface Geopotential (z)   | Float 64 |

### 2.1.5 QI Data

*Table 2-5 – QI Data*

| Field Name                       | Documentation  | Type          |
|----------------------------------|--|---------------|
| MSK_QUALIT_BXX<br>(Sen2Cor 2.10) | List of band-depended quality masks to populate the L2A SCL defective pixel class. | Integer (0,1) |

### 2.1.6 Output Data

Outputs are classified specifically for the corresponding procedures in the equivalent sections for the sub modules.

### 2.1.7 Command Line Parameters

In the following Table 2-6, the list of the command line parameters can be found. Lists are provided for both the PDGS and Toolbox modes.

*Table 2-6 – Command Line Parameters*

| Command Line Parameters (“Toolbox” mode. L1C product as input_dir) |
|--|
| L2A_Process --h  |

```
usage: L2A_Process.py [-h] [--mode MODE] [--resolution {10,20,60}]
                    [--datastrip DATASTRIP] [--tile TILE]
                    [--output_dir OUTPUT_DIR] [--work_dir WORK_DIR]
                    [--img_database_dir IMG_DATABASE_DIR]
                    [--res_database_dir RES_DATABASE_DIR]
                    [--processing_centre PROCESSING_CENTRE]
                    [--archiving_centre ARCHIVING_CENTRE]
                    [--processing_baseline PROCESSING_BASELINE] [--raw]
                    [--tif] [--sc_only] [--sc_classic] [--sc_cog]
                    [--cr_only] [--debug] [--GIP_L2A GIP_L2A]
                    [--GIP_L2A_SC GIP_L2A_SC] [--GIP_L2A_AC GIP_L2A_AC]
                    [--GIP_L2A_PB GIP_L2A_PB]
                    input_dir

Sen2Cor. Version: 2.12.03, created: 2024.09.09, supporting Level-1C product version 14.2 - 15.0.
positional arguments:
  input_dir              Directory of Level-1C input
optional arguments:
  -h, --help            show this help message and exit
  --mode MODE           Mode: generate_datastrip, process_tile
  --resolution {10,20,60}
                        Target resolution, can be 10, 20 or 60m. If omitted,
                        only 20 and 10m resolutions will be processed
  --datastrip DATASTRIP
                        Datastrip folder
  --tile TILE           Tile folder
  --output_dir OUTPUT_DIR
                        Output directory
  --work_dir WORK_DIR   Work directory
  --img_database_dir IMG_DATABASE_DIR
                        Database directory for L1C input images
  --res_database_dir RES_DATABASE_DIR
                        Database directory for results and temporary products
  --processing_centre PROCESSING_CENTRE
                        Processing centre as regex: ^[A-Z]{4}$, e.g "SGS_"
  --archiving_centre ARCHIVING_CENTRE
                        Archiving centre as regex: ^[A-Z]{4}$, e.g. "SGS_"
  --processing_baseline PROCESSING_BASELINE
                        Processing baseline in the format: "dd.dd", where
                        d=[0:9]
  --raw                Export raw images in rawl format with ENVI hdr
  --tif                Export raw images in TIFF format instead of JPEG-2000
  --sc_only            Performs only the scene classification at 60 or 20m
                        resolution
  --sc_classic         Performs scene classification in Sen2Cor 2.9 mode
  --sc_cog             Export SCL image in COG format instead of JPEG_2000
  --cr_only            Performs only the creation of the L2A product tree, no
                        processing
  --debug             Performs in debug mode
  --GIP_L2A GIP_L2A   Select the user GIPP
  --GIP_L2A_SC GIP_L2A_SC
                        Select the scene classification GIPP
  --GIP_L2A_AC GIP_L2A_AC
                        Select the atmospheric correction GIPP
  --GIP_L2A_PB GIP_L2A_PB
                        Select the processing baseline GIPP
```

## 2.2 Scene Classification

### 2.2.1 Input Data

L1C Image data as specified in Section 2.1.1, resampled to the requested resolution of 60, 20, 10 m.

### 2.2.2 GIPP

Figure 2 shows the GIPP of the Scene Classification Module, while Table 2-7 describes the related input.

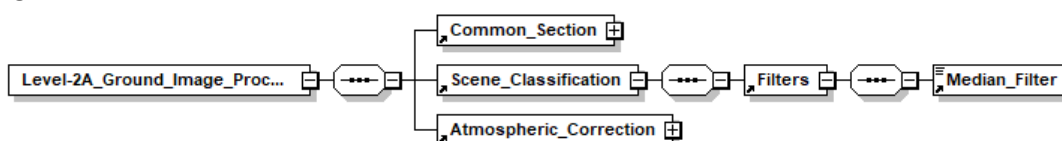

Generated by XMLSpy

www.altova.com

Figure 2 – GIPP of Scene Classification

|   |  |  |
|---|--|--|
|  | <p><b>Optical MPC</b></p> <p><b>Sen2Cor 2.12.03 Input-Output Data Definition</b></p> | <p>Ref.: OMPC.TPZG.IOD.002<br/> Issue: 1.0<br/> Date: 10/09/2024<br/> Page: 13</p> |
|---|--|--|

For a full list of all types, parameters and default values, please consult the L2A\_GIPP.xml embedded PDF in 3.4. With and since Sen2Cor 2.11 the improved Scene Classification Evolution is used as default. User can switch to the classic algorithm by the command line `--sc_classic`. From Sen2Cor 2.10, the dedicated optional command line (`--sc_cog`) saves the Scene Classification output in COG (Cloud Optimized Geotiff) format.

**Table 2-7 – GIPP of Scene Classification**

| Field Name    | Documentation                                       | Type   |
|---------------|---|--|
| Median_Filter | Digital Filter for smoothing of Classification map. | Unsigned Integer, recommended values 0:3, Default: 0 |

### 2.2.2.1 Expert Level

GIPP for the Scene Classification on Expert Level are separated from the standard User level and are collected in a different file, named `L2A_CAL_SC_GIPP.xml`. Whereas `L2A_GIPP.xml` is a pure user configuration file and thus is available for a standard user, the Expert level GIPPs are reserved for testing and calibration campaigns. Wrong calibrations might lead to heavy performance artefacts. The description of these parameters is thus postponed to Section 3.1 and standard users are warned to leave these calibration parameters untouched. For a full list of all GIPPs including their types, values, and ranges, please consult the embedded PDF in section 3.4.

### 2.2.3 Metadata

Quality Information data on Tile level are part of the Tile metadata as summarized in Figure 3. The Entries represent the percentage of classified pixels as listed for Table 2-10, related to the total amount of data pixels (100 %).

Quality Information data on User Product level are part of the User product Metadata. The structure follows the QI Data on Tile level as displayed in Figure 3. Additional metadata are specified in Section 2.1.3 and Table 3-1.

### 2.2.4 Cython Library

Since Sen2Cor 2.10, a new scene classification has been implemented. This requires a dedicated library (`topographicshadows_cython_03`) that is provided for each available operating system.

### 2.2.5 Auxiliary Data

The ESACCI-LC for Sen2Cor data package is prepared for users of Sen2Cor version starting with sen2Cor 2.5.5 which want to benefit from the last improvements of Sen2Cor Cloud Screening and Classification module. This auxiliary data information is used in Sen2Cor to improve the accuracy of Sen2Cor classification over water, urban and bare areas and to have a better handling of false detection of snow pixels.

|   |  |  |
|---|--|--|
|  | <p><b>Optical MPC</b></p> <p><b>Sen2Cor 2.12.03 Input-Output Data Definition</b></p> | <p>Ref.: OMPC.TPZG.IOD.002<br/> Issue: 1.0<br/> Date: 10/09/2024<br/> Page: 14</p> |
|---|--|--|

**Version 2.10 (and up):**

For users of Sen2cor since version 2.10 (and up), the updated tar file ESACCI-LC-L4-ALL-FOR-SEN2COR-2.10.tar is available for download from this location:

<https://earth.esa.int/eogateway/ftp/Sentinel-2/ESACCI-LC-L4-ALL-FOR-SEN2COR-2.10.tar.gz>

The updated tar file including the updated snow monthly climatology shall be extracted at the following location of Sen2cor installation: '\$SEN2COR\_BIN/aux\_data'.

It contains two files and one directory:

- [ESACCI-LC-L4-LCCS-Map-300m-P1Y-2015-v2.0.7.tif](#)
- [ESACCI-LC-L4-WB-Map-150m-P13Y-2000-v4.0.tif](#)
- [ESACCI-LC-L4-Snow-Cond-500m-MONTHLY-2000-2012-v2.4](#)

In L2A\_CAL\_SC\_GIPP.xml, the reference to the Snow climatology has been updated with the replacement of the ESA CCI Snow Weekly Condition by a derived Snow Monthly climatology.

```
<ESACCI_SnowCondition_Map_Dir>ESACCI-LC-L4-Snow-Cond-500m-MONTHLY-2000-2012-v2.4</ESACCI_SnowCondition_Map_Dir>
```

**Versions 2.5.5, 2.8, 2.9:**

The original ESACCI-LC for Sen2Cor data package (ESACCI-LC-L4-ALL-FOR-SEN2COR.zip) is available for download from this location:

<http://maps.elie.ucl.ac.be/CCI/viewer/download.php>

This zip file shall then be extracted at this location of Sen2Cor installation: '\$SEN2COR\_BIN/aux\_data/'

It contains two files and one directory:

- [ESACCI-LC-L4-LCCS-Map-300m-P1Y-2015-v2.0.7.tif](#)
- [ESACCI-LC-L4-WB-Map-150m-P13Y-2000-v4.0.tif](#)
- [ESACCI-LC-L4-Snow-Cond-500m-P13Y7D-2000-2012-v2.0](#)

Example on a Ubuntu (Linux) installation:

```
$ ls Sen2Cor-02.08.00-Linux64/lib/python2.7/site-packages/sen2cor/aux_data
ESACCI-LC-L4-LCCS-Map-300m-P1Y-2015-v2.0.7.tif
ESACCI-LC-L4-Snow-Cond-500m-P13Y7D-2000-2012-v2.0
ESACCI-LC-L4-WB-Map-150m-P13Y-2000-v4.0.tif
```

Example on a Windows 7 installation:

```
>dir Sen2Cor-02.08.00-Linux64/lib/python2.7/site-packages/sen2cor/aux_data
ESACCI-LC-L4-LCCS-Map-300m-P1Y-2015-v2.0.7.tif
ESACCI-LC-L4-Snow-Cond-500m-P13Y7D-2000-2012-v2.0
ESACCI-LC-L4-WB-Map-150m-P13Y-2000-v4.0.tif
```

**NOTE-1:** Please note that a Digital Elevation Model (DEM) is a pre-requisite for using ESACCI\_LC information in the Scene Classification algorithm. In the case SRTM DEM is used, latitudes higher > 60 deg

|   |  |  |
|---|--|--|
|  <p><b>OPT-MPC</b><br/>Optical Mission Performance Cluster</p> | <p><b>Optical MPC</b></p> <p><b>Sen2Cor 2.12.03 Input-Output Data Definition</b></p> | <p>Ref.: OMPC.TPZG.IOD.002<br/> Issue: 1.0<br/> Date: 10/09/2024<br/> Page: 15</p> |
|---|--|--|

N (and lower < 60 deg S) are not covered by the SRTM DEM, therefore no ESACCI\_LC information will be used for these latitudes. Standard Scene Classification algorithm will then be applied.

**NOTE-2:** Please note that it is possible to use symbolic links in this aux\_data folder if you prefer to copy those auxiliary files to another data folder. (unix command: ln -s, windows command: mklink)



Figure 3 – QI Data of Tile and User Product Metadata

2.2.6 Output Data

**Table 2-8 – Cloud Probability map**

| Cloud Probability [QI Data] |              |
|-----------------------------|--------------|
| Unit                        | percentage   |
| Range                       | 0 - 100      |
| Sampling                    | 8 bit/sample |
| Resolution                  | 60 m, 20 m   |

**Table 2-9 – Snow Probability map**













| Snow Probability [QI Data] |              |
|----------------------------|--------------|
| Unit                       | percentage   |
| Range                      | 0 – 100      |
| Sampling                   | 8 bit/sample |
| Resolution                 | 60 m, 20 m   |

**Table 2-10 – Scene Classification**

| Scene Classification [Image Data] |             |
|-----------------------------------|-------------|
| Unit                              | enumeration |



**Scene Classification [Image Data]**

|            |              |   |   |
|------------|--------------|---|---|
| Range      | 0            | No Data (Missing data on projected tiles) (black) |    |
|            | 1            | Saturated or defective pixel (red)                |    |
|            | 2            | Cast Shadows (very dark grey)                     |    |
|            | 3            | Cloud shadows (dark brown)                        |    |
|            | 4            | Vegetation (green)                                |    |
|            | 5            | Not vegetated (dark yellow)                       |    |
|            | 6            | Water (dark and bright) (blue)                    |    |
|            | 7            | Unclassified (dark grey)                          |    |
|            | 8            | Cloud medium probability (grey)                   |    |
|            | 9            | Cloud high probability (white)                    |   |
|            | 10           | Thin cirrus (very bright blue)                    |  |
|            | 11           | Snow or ice (very bright pink)                    |  |
| Sampling   | 8 bit/sample |   |   |
| Resolution | 60 m, 20 m   |   |   |

## 2.3 Atmospheric Correction

### 2.3.1 Input Data

L1C Image data as specified in Section 2.1.1, resampled to the requested resolution of 60, 20, 10 m. Scene Classification as specified in Section 2.2 resampled to the requested resolution of 60, 20, 10 m.

### 2.3.2 GIPP

Figure 4 shows the overall GIPP of the Atmospheric Correction Module. Table 2-11 reports the GIPP selection for the look-up tables.

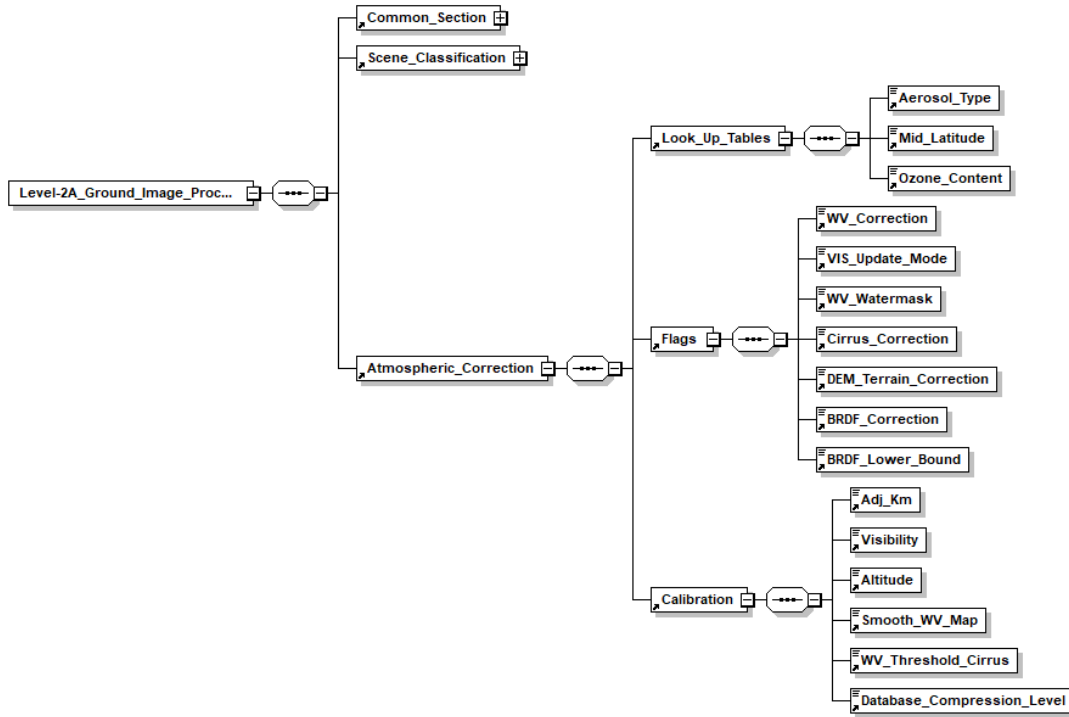

Generated by XMLSpy [www.altova.com](http://www.altova.com)

Figure 4 – GIPP for Atmospheric Correction Module

Table 2-11 – GIPP for selection of Look\_Up\_Tables

| Field Name   | Documentation   | Type                                   |
|--------------|---|--|
| Aerosol_Type | The aerosol type used for atmospheric correction: a selection of AUTO will perform an automated aerosol type determination for this parameter as described in the SUM for Section 2.2.3.2. Default is: RURAL. | Choice:<br>RURAL,<br>MARITIME,<br>AUTO |
| Mid_Latitude | The mid latitude used for atmospheric correction a selection of AUTO will perform an automated aerosol type determination for this parameter as described in the SUM for Section 2.2.3.2. Default is: SUMMER  | Choice:<br>SUMMER,<br>WINTER,<br>AUTO  |

| Field Name               | Documentation   | Type         |     |     |                   |                   |     |     |                 |
|--------------------------|---|--------------|-----|-----|-------------------|-------------------|-----|-----|-----------------|
| Ozone_Content,<br>Summer | <p>The atmospheric temperature profile and ozone content for Mid_Latitude Summer Atmosphere.</p> <p>Default is: 0, which takes the best approximation from the ECMWFT metadata in the AUX_DATA folder of the input product. Otherwise the user can set the following numerical values:</p> <table border="1"> <thead> <tr> <th>Dobson Units</th> </tr> </thead> <tbody> <tr><td>250</td></tr> <tr><td>290</td></tr> <tr><td>331 (standard MS)</td></tr> <tr><td>370</td></tr> <tr><td>410</td></tr> <tr><td>450</td></tr> </tbody> </table> | Dobson Units | 250 | 290 | 331 (standard MS) | 370               | 410 | 450 | Choice as given |
| Dobson Units             |   |              |     |     |                   |                   |     |     |                 |
| 250                      |   |              |     |     |                   |                   |     |     |                 |
| 290                      |   |              |     |     |                   |                   |     |     |                 |
| 331 (standard MS)        |   |              |     |     |                   |                   |     |     |                 |
| 370                      |   |              |     |     |                   |                   |     |     |                 |
| 410                      |   |              |     |     |                   |                   |     |     |                 |
| 450                      |   |              |     |     |                   |                   |     |     |                 |
| Ozone_Content,<br>Winter | <p>The atmospheric temperature profile and ozone content for Mid_Latitude Summer Atmosphere.</p> <p>Default is 0, which takes the best approximation from the ECMWFT metadata in the AUX_DATA folder of the input product. Otherwise the user can set the following numerical values:</p> <table border="1"> <thead> <tr> <th>Dobson Units</th> </tr> </thead> <tbody> <tr><td>250</td></tr> <tr><td>290</td></tr> <tr><td>330</td></tr> <tr><td>377 (standard MW)</td></tr> <tr><td>420</td></tr> <tr><td>460</td></tr> </tbody> </table>  | Dobson Units | 250 | 290 | 330               | 377 (standard MW) | 420 | 460 | Choice as given |
| Dobson Units             |   |              |     |     |                   |                   |     |     |                 |
| 250                      |   |              |     |     |                   |                   |     |     |                 |
| 290                      |   |              |     |     |                   |                   |     |     |                 |
| 330                      |   |              |     |     |                   |                   |     |     |                 |
| 377 (standard MW)        |   |              |     |     |                   |                   |     |     |                 |
| 420                      |   |              |     |     |                   |                   |     |     |                 |
| 460                      |   |              |     |     |                   |                   |     |     |                 |

For a full list of all types, parameters, and default values, please consult the embedded L2A\_GIPP.xml in PDF format, in section 3.4.

### 2.3.2.1 Expert Level

GIPP for the Atmospheric Correction on Expert Level are separated from the standard User level and are collected in a different file, named L2A\_CAL\_AC\_GIPP.xml. Whereas L2A\_GIPP.xml is a pure user configuration file and thus is available for a standard user, the Expert level GIPPs are reserved for testing and calibration campaigns. Wrong calibrations might lead to heavy performance artefacts. The description of these parameters is thus postponed to Section 3.1 and standard users are warned to leave these calibration parameters untouched. For a full list of all GIPPs including their types, values and ranges, please consult the embedded PDF in section 3.4.

### 2.3.3 Metadata

NA

### 2.3.4 Auxiliary Data (Look Up Tables)

The algorithm for the atmospheric correction relies on a database of radiative transfer calculations using the DISORT 8-stream algorithm combined with the correlated k method. This has been converted to atmospheric LUTs based on the freely available `libRadtran` library.

**Table 2-12 – Parameter space for atmospheric correction**

| Parameter              | Range       | Increment / grid points          |
|------------------------|-------------|----------------------------------|
| Solar zenith angle     | 0 -70°      | 10°                              |
| Sensor view angle      | 0 -10°      | 10°                              |
| Relative azimuth angle | 0 -180°     | 30° (180°= backscatter)          |
| Ground elevation       | 0 -2.5 km   | 0.5 km                           |
| Visibility             | 5 -120 km   | 5, 7, 10, 15, 23, 40, 80, 120 km |
| Water vapour, summer   | 0.4 -5.5 cm | 0.4, 1.0, 2.0, 2.9, 4.0, 5.0 cm  |
| Water vapour, winter   | 0.2 -1.5 cm | 0.2, 0.4, 0.8, 1.1 cm            |

The baseline processing uses the mid-latitude summer (MS) atmospheric temperature / humidity profile with scaled water vapour columns of 0.4, 1.0, 2.0, 2.9, 4.0, and 5.0 cm (sea level geometry). A separate LUT file is used for each water vapour concentration. The baseline aerosol type is rural (continental). Calculations are performed for the ground elevations 0 – 2.5 km above sea level, in steps of 0.5 km. The default value of the ozone content is 331 DU (for sea level, decreasing with elevation). The water vapour dependent LUTs are used during the per-pixel water vapour retrieval for Sentinel-2 scenes.

The baseline LUTs are compiled for the rural aerosol and the mid-latitude summer (MS) atmosphere with its corresponding ozone column (331 DU for sea level). Other LUTs are selectable via configuration.

Water vapour columns are calculated using an equidistant 100 m grid.

LUT file name conventions: a name consists of 16 characters or numbers followed by the extension ‘.atm’. The first character defines the atmospheric temperature profile (e.g. h=summer, w=winter) and ozone content, followed by ‘99000’ (indicating the symbolic satellite height of 99,000 m), followed by ‘\_’, then ‘wvxy’ where xy is the sea-level water vapour column, followed by ‘\_’ and a 4 letter aerosol identifier ‘\_rura’.

**Table 2-13 – LUT file naming conventions**

| Examples:            |   |
|----------------------|---|
| h99000_wv29_rura.atm | MS atmosphere, water vapour=2.9 cm, rural, ozone=331 DU |

| Examples:   |   |
|---|---|
| w99000_wv11_rura.atm  | MW atmosphere, water vapour=1.1 cm, rural, ozone=377 DU |
| Names for other aerosol types are coded with 4 letters, e.g.: |   |
| h99000_wv29_mari.atm  | MS, water vapour=2.9 cm, maritime, ozone=331 DU         |
| h99000_wv29_urba.atm <sup>1</sup>                             | MS, water vapour=2.9 cm, urban, ozone=331 DU            |
| h99000_wv29_dese.atm <sup>1</sup>                             | MS, water vapour=2.9 cm, desert, ozone=331 DU           |

The content are the following 6 radiative transfer functions for different atmospheric conditions, view angles 0° (nadir) and 10° off-nadir, and a range of solar geometries and relative azimuth angles.

**Table 2-14 – Structure and format of the atmospheric LUT files**

| Column |      | Content   |
|--------|------|---|
| 1.     | Lp   | path radiance   |
| 2.     | Edf  | diffuse flux at the sensor = (Tdir + Tdif)*Edif (where Edf is the diffuse solar flux at the ground)   |
| 3.     | Edr  | direct (beam) irradiance at the sensor= (Tdir + Tdif) * Tsun * E<br>Where:<br>Tsun is the sun-to-ground direct transmittance,<br>E = extra-terrestrial solar irradiance |
| 4.     | Tdir | direct transmittance ground-to-sensor   |
| 5.     | Tdif | diffuse transmittance ground-to-sensor  |
| 6.     | s    | spherical albedo of atmosphere  |

- ❖ The radiance, irradiance, and flux values are calculated for an earth-sun distance of 1 astronomical unit.
- ❖ Each LUT file stores the radiative transfer functions as float numbers in the binary platform independent XDR format.
- ❖ The Thuillier-2003 extra-terrestrial solar irradiance spectrum is used for the calculation of the LUTs (see Ref. Thuillier et al. 2003). It has been provided by ESA expressed in  $mW \cdot m^{-2} \cdot nm^{-1}$  resampled at 1 nm.

<sup>1</sup> Currently not compiled

|   |  |  |
|---|--|--|
|  | <p><b>Optical MPC</b></p> <p><b>Sen2Cor 2.12.03 Input-Output Data Definition</b></p> | <p>Ref.: OMPC.TPZG.IOD.002<br/> Issue: 1.0<br/> Date: 10/09/2024<br/> Page: 23</p> |
|---|--|--|

LUTs are calculated for:

- ❖ ne = 6 elevations (0-2.5 km, increment 0.5 km),
- ❖ nz = 8 solar zenith angles (0-70°, increment 10°),
- ❖ nv = 8 visibilities (5, 7, 10, 15, 23, 40, 80, 120 km), and
- ❖ nb bands: nb=12 for the 60 m data; nb=12 for the 20 m data; nb=4 for the 10 m data of Sentinel-2.

The sequence of data is arranged in a file with 104 columns and nz\* nv\* nb lines:

**Table 2-15 – Column structure of atmospheric LUT files**

| Column           | Content  |
|------------------|--|
| column 1         | Solar zenith angle (first 0°, last 70°)  |
| column 2         | Visibility (first 5 km, last 120 km)   |
| columns 3 – 8    | Lp, Edf, Edr, Tdr, Tdf, s (nadir view), elevation=0 km   |
| columns 9 – 19   | Edf, Edr, Tdr, Tdf, Lp for 7 rel. azimuth angles 0(30)180°, at sensor view angle 10°, elevation = 0 km |
| columns 20 – 104 | Columns 3 – 19 are repeated 5 times for the remaining elevations 0.5 to 2.5 km (increment 0.5 km)      |

Note: the spherical albedo s is the same for nadir and 10° off-nadir, therefore it is stored only once.

The contents of the file are written as a simple float binary array LUT = fltarr(2+17 \* ne, nz, nv, nb) where the 17 radiative transfer functions are calculated for different parameter sets with ne (first=fastest loop = elevation), nz (second loop = solar zenith), nv (third loop = visibility) and nb (last loop = spectral band). Look Up Tables are located in two folders named lib\_S2A and lib\_S2B (for Sentinel 2A and Sentinel 2B satellites) as Sen2Cor subdirectories. These directories should never be changed or removed as they are essential for a proper atmospheric correction. Since Sen2Cor version 2.12.01, there is a third folder named lib\_S2C for the Sentinel 2C MSI.

### 2.3.5 Output Data

Outputs are specified in the following subsections for the individual sub modules.

### 2.3.6 Aerosol Optical Thickness Retrieval

The aerosol optical thickness ( $\tau$ ) is defined as the integrated extinction coefficient over a vertical column of atmosphere of unit cross section. Extinction coefficient is the fractional depletion of radiance per unit path length (also called attenuation for radar frequencies). Example in formula:

$$I = I_0 (e^{-\tau})$$

If not enough Dense Dark Vegetation (DDV) pixels are available, Sen2Cor 2.11 switches to external sources. Starting with L1C Processing baseline (PB) 4.00, Total Aerosol Optical Thickness is provided as input in the L1C product in the Granule/Tile/Aux\_data where the related Copernicus Atmosphere Monitoring Service (CAMS) file is present. Sen2Cor 2.11 retrieves from this file the *aerosol optical thickness* at 550 nm and the *geopotential (z)*.

### 2.3.6.1 Input Data

Band subset as specified in Section 2.1.1, resampled to corresponding resolution of 60, 20, 10 m (see Table 15 – Band subsets).

**Table 2-16 – Band subsets**

| CAMSxx             | Purpose in L2A Processing context          |
|--------------------|--|
| B2 (490nm): 10 m   | Sensitive to Vegetation Aerosol Scattering |
| B4 (665nm): 10 m   | Max Chlorophyll absorption                 |
| B12 (2190nm): 20 m | AOT determination                          |

Input retrieval in Sen2Cor 2.11 from the CAMS auxiliary file in case the number of DDV pixels is less than 1% (see Table 2-17).

**Table 2-17 – CAMS auxiliary input**

| Variable and Raster Band number | Purpose in L2A processing context    |
|---------------------------------|--------------------------------------|
| AOD550                          | To retrieve the visibility map/index |
| Geopotential (z)                | To retrieve the visibility map/index |

### 2.3.6.2 GIPP

Figure 5– GIPP for selection of Look\_Up\_Tables, shows the GIPP of the Atmospheric Correction Module for the selection of the Look Up Tables (LUTs).

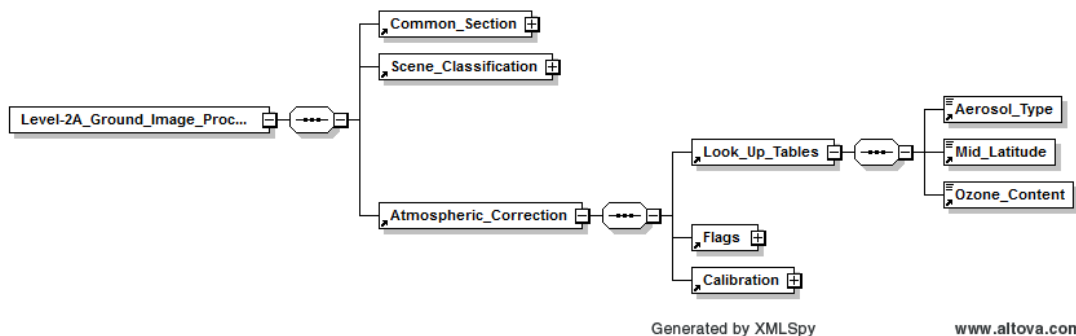

**Figure 5 – GIPP for selection of Look\_Up\_Tables**

### 2.3.6.3 Metadata

Metadata are specified in Table 2-3.

### 2.3.6.4 Output Data

**Table 2-18 – Aerosol Optical Thickness (AOT) map**

| Aerosol Optical Thickness (AOT) Map [Image Data] |  |
|--|--|
| Unit   | Unit less                              |
| Range  | AOT = DN / 1000                        |
| Sampling   | 16 bit/pixel                           |
| Resolution                                       | 60 m, 20 m, 10 m (resampled from 20 m) |

### 2.3.7 Water Vapour Retrieval

WV retrieval over land is performed with the Atmospheric Pre-corrected Differential Absorption algorithm (APDA) which is applied to the two Sentinel-2 bands B8A, and B9 (Fig. 4). Band 8A is the reference channel in an atmospheric window region. Band B9 is the measurement channel in the absorption region. The absorption depth is evaluated by calculating the radiance for an atmosphere with no WV, assuming that the surface reflectance for the measurement channel is the same as for the reference channel. The absorption depth is then a measure of the WV column content.

Typical ranges of water vapour columns are (sea-level-to space):

**Table 2-19 – WVP columns**

| Conditions               | WVP (cm)  |
|--------------------------|-----------|
| tropical                 | 3 - 5     |
| midlatitude, summer      | 2 - 3     |
| dry summer, spring, fall | 1 – 1.5   |
| dry desert or winter     | 0.3 – 0.8 |

#### 2.3.7.1 Input Data

Band subsets are specified in Section 2.1.1, resampled to corresponding resolution of 60, 20 m.



**Table 2-20 – Band subsets**

| Channels and Resolution | Purpose in L2A processing context                                    |
|-------------------------|--|
| B8A (865nm): 20 m       | Used for water vapour absorption (reference channel)                 |
| B9 (945nm): 60 m        | Water Vapour absorption atmospheric correction (measurement channel) |

**2.3.7.2 GIPP**

**Table 2-21 – GIPP input fields**

| Field Name    | Documentation   | Type  |
|---------------|---|---|
| WV_Correction | 0: no water vapour correction<br>1: water vapour correction using band B8A  | Enumerator<br>0,1 as stated, default: 1   |
| WV_Watermask  | A choice to set the water vapour values for water pixels:<br>0 = not replaced,<br>1 = average water vapour value of land pixels is assigned to water pixels,<br><del>2 = line average of water vapour of land pixels is assigned to water pixels.</del><br>Only available with WV_Correction mode 1 | Enumerator<br>1,2, as stated<br>1: default<br>2: for future use, currently unused |
| Smooth_WV_Map | smooth water vapour map [m]   | Floating point, 32 bit,<br>default: 100 m   |

**2.3.7.3 Metadata**

None

**2.3.7.4 Output Data**

**Table 2-22 – Water Vapour Map**

| Water Vapour Map [Image Data] |                  |
|-------------------------------|------------------|
| Unit                          | Dimensionless    |
| Range                         | 0.3 – 6.5 cm     |
| Sampling                      | 16 bit           |
| Resolution                    | 60 m, 20 m, 10 m |

### 2.3.8 Cirrus Correction

#### 2.3.8.1 Input Data

*Table 2-23 – Band subset*

| Channels and Resolution | Purpose in L2A processing context                   |
|-------------------------|---|
| B10 (1375): 60 m        | Detection of thin cirrus for atmospheric correction |

#### 2.3.8.2 GIPP

*Table 2-24 – Inputs parameter cirrus correction*

| Field Name          | Documentation   | Type  |
|---------------------|---|---|
| Cirrus_Correction   | Flag for cirrus removal<br>TRUE: enabled<br>FALSE: disabled | Restricted string, TRUE / FALSE as stated   |
| WV_Threshold_Cirrus | Water Vapour threshold to switch cirrus algorithm off [%]   | Floating point value, 32 bit, default: 0.25 |

#### 2.3.8.3 Metadata

None

#### 2.3.8.4 Output Data

Contribution of cirrus correction to Surface Reflectance for individual channels as listed in Section 2.3.10. The Cirrus band itself will be omitted in the Level 2A output, as it does not contain surface reflectance information and no direct user output.

### 2.3.9 Terrain Correction

#### 2.3.9.1 Input Data

See metadata Section 2.3.9.3 below.

#### 2.3.9.2 GIPP

**Table 2-25 – GIPP terrain correction**

| Field Name             | Documentation  | Type  |
|------------------------|--|---|
| DEM_Directory          | Directory where DEM will be expected. If set to 'NONE', no DEM is used and no terrain correction will be performed.<br>Example: 'dem/CopernicusDEM90_DGED'   | Formatted string  |
| DEM_Reference          | Example of url: <a href="https://copernicus-dem-90m.s3.eu-central-1.amazonaws.com/">https://copernicus-dem-90m.s3.eu-central-1.amazonaws.com/</a>  | Formatted string  |
| DEM_Terrain_Correction | Boolean Flag for using DEM for terrain correction. Otherwise only used for scene classification and AOT  | Formatted string  |
| Altitude               | Assumed altitude if no DEM is present [km]   | Floating point value, 32 bit, default: 0.10, equals 100 m |
| BRDF_Correction        | <p>Empirical BRDF correction with factor (G) according to following equation:<br/> <math display="block">G = \{ \cos(\beta_i) / \cos(\beta_T) \}^b \geq g \quad (\text{eq. 1})</math>           where:<br/> <math>\beta_i</math>: local solar zenith angle (from metadata, Section 1.1.3).<br/> <math>\beta_T</math>: threshold for surface reflectance (determined programmatically).<br/>           b: exponent, set via options below.<br/>           g: Lower boundary of BRDF correction factor, recommended between 0.2 and 0.25 (see next parameter, below).</p> <p><u>Options to be selected (Exponent b):</u><br/>           0: no empirical BRDF correction (or flat terrain)<br/>           1: correction with cosine of local solar zenith angle (eq. 1 with b=1)<br/>           2: correction with sqrt(cos) of local solar zenith angle (eq. 1 with b=1/2 correction).</p> | Enumerator<br>0, 1, 2                                     |
| BRDF_Lower_Bound       | Lower boundary of BRDF correction factor, should be between 0.2 and 0.25.  | Float, default 0.22                                       |

### 2.3.9.3 Metadata

- DEM (as specified in the GIPP, will be internally prepared and adapted to geo-positional coordinates obtained from the JPEG-2000 image headers)
- Terrain Shadow Map (calculated internally via GDAL)
- Slope Map (calculated internally via GDAL)

|   |  |  |
|---|--|--|
|  | <p><b>Optical MPC</b></p> <p><b>Sen2Cor 2.12.03 Input-Output Data Definition</b></p> | <p>Ref.: OMPC.TPZG.IOD.002<br/> Issue: 1.0<br/> Date: 10/09/2024<br/> Page: 29</p> |
|---|--|--|

- Aspect Map (calculated internally via GDAL)

### 2.3.9.4 Output Data

Corrections of Surface Reflectance retrieval for bands B01 – B12, except B10) as listed in Section 2.3.10. No separate user output.

## 2.3.10 Surface Reflectance (Hemispherical-directional reflectance factor, HDRF)

### 2.3.10.1 Input Data

#### 60, 20 m Resolution

- ❖ Full set of Bands as specified in Section 2.1.1, Table 2-1, (except Band 8) resampled to corresponding resolution;
- ❖ Aerosol Map as specified in Table 2-18;
- ❖ Water Vapour Map as specified in Table 2-22;
- ❖ (Optional) Cirrus correction as specified in Section 2.3.8.4;
- ❖ (Optional) Terrain correction as specified in Section 2.3.9.4.

#### 10 m Resolution

- ❖ Bands 2,3,4,8 as specified in Section 2.1.1, Table 1, no resampling;
- ❖ Resampled Aerosol Map as specified in Table 2-18;
- ❖ Water Vapour Map as specified in Table 2-22;
- ❖ (Optional) Terrain correction as specified in Section 2.3.9.4

### 2.3.10.2 GIPP

*Table 2-26 – GIPP surface reflectance*

| Field Name | Documentation  | Type                                 |
|------------|--|--------------------------------------|
| Adj_Km     | Range of adjacency effect (reflected radiation from neighbourhood) in [km] | Floating point, 32 bit, Default: 1.0 |

### 2.3.10.3 Metadata

None

**2.3.10.4 Output Data**

**Table 2-27 – Outputs surface reflectance**

| Name                  | Level-2A   |
|-----------------------|--|
| Product               | L2A, Surface reflectance   |
| Coverage              | Regional. 110 km x 110 km  |
| Packaging             | MGRS Tiles (same area coverage as Level 1C input data)   |
| Geo-location accuracy | Identical to the level 1C geo-location performance   |
| Frequency             | 5 days repeat cycle with two Sentinel-2 satellites   |
| Format                | <p>OpenJPEG 2.1.2 details @60 m processing:</p> <p>Codestream, export Band 1, res 60m:<br/>SOC marker segment @ (1866, 0)<br/>SIZ marker segment @ (1868, 41)<br/>Profile: no profile<br/>Reference Grid Height, Width: (1830 x 1830)<br/>Vertical, Horizontal Reference Grid Offset: (0 x 0)<br/>Reference Tile Height, Width: (192 x 192)<br/>Vertical, Horizontal Reference Tile Offset: (0 x 0)<br/>Bitdepth: (16,)<br/>Signed: (False,)<br/>Vertical, Horizontal Subsampling: ((1, 1),)<br/>COD marker segment @ (1911, 18)<br/>Coding style:<br/>Entropy coder, with partitions<br/>SOP marker segments: False<br/>EPH marker segments: False<br/>Coding style parameters:<br/>Progression order: LRCP<br/>Number of layers: 1<br/>Multiple component transformation usage: no transform specified<br/>Number of resolutions: 6<br/>Code block height, width: (4 x 4)<br/>Wavelet transform: 5-3 reversible<br/>Precinct size: ((64, 64), (64, 64), (64, 64), (64, 64), (64, 64), (64, 64))<br/>Code block context:<br/>Selective arithmetic coding bypass: False<br/>Reset context probabilities on coding pass boundaries: False<br/>Termination on each coding pass: False<br/>Vertically stripe causal context: False<br/>Predictable termination: False<br/>Segmentation symbols: False<br/>QCD marker segment @ (1931, 19)<br/>Quantization style: no quantization, 2 guard bits<br/>Step size: [(0, 16), (0, 17), (0, 17), (0, 18), (0, 17), (0, 17), (0, 17), (0, 18), (0, 17), (0, 17), (0, 18), (0, 17), (0, 18), (0, 17), (0, 18), (0, 17), (0, 17), (0, 18)]<br/>CME marker segment @ (1952, 37)</p> |
| Unit                  | Dimensionless, Unsigned Integer  |
| Calibration and Range | 1 / 10.000: i.e.: Digital Numbers 0 : 10.000, representing radiometric reflectance values from 0.0 to 1.0  |
| Sampling              | 16 bits / pixel  |

| Name                     | Level-2A   |
|--------------------------|--|
| Input resolution         | Generated output resolution                                    |
| B1 (443nm):<br>60 m      | 60 m, 20 m (since Sen2Cor 2.10)                                |
| B2 (490nm):<br>10 m      | 60 m, 20 m, 10 m   |
| B3 (560nm):<br>10 m      | 60 m, 20 m, 10 m   |
| B4 (665nm):<br>10 m      | 60 m, 20 m, 10 m   |
| B5 (705nm):<br>20 m      | 60 m, 20 m   |
| B6 (740nm):<br>20 m      | 60 m, 20 m   |
| B7 (783nm):<br>20 m      | 60 m, 20 m   |
| B8 (842nm):<br>10 m      | 10 m   |
| B8a<br>(865nm): 20<br>m  | 60 m, 20 m   |
| B9 (945nm):<br>60 m      | 60 m   |
| B10 (1375):<br>60 m      | No output generated as it does not contain surface information |
| B11<br>(1610nm):<br>20 m | 60 m, 20 m   |
| B12<br>(2190nm):<br>20 m | 60 m, 20 m   |



|   |  |  |
|---|--|--|
|  | <h2 style="color: #0070C0;">Optical MPC</h2> <h3 style="color: #70AD47;">Sen2Cor 2.12.03 Input-Output Data Definition</h3> | <p>Ref.: OMPC.TPZG.IOD.002<br/> Issue: 1.0<br/> Date: 10/09/2024<br/> Page: 33</p> |
|---|--|--|

## 2.4 Quality Mask

---

Since version 2.10, Sen2Cor supports and handles L1C Quality Masks in raster format describing invalid pixels in the L1C input data.

### 2.4.1 Input Data

L1C\_product/GRANULE/tile\_id/QI\_DATA/ contain MSK\_QUALIT\_BXX.jp2 (where XX is the ID of the bands) type files. The files with the affected bands are open and a mask is created.

### 2.4.2 GIPP

The L2A\_GIPP.xml configuration file contains a new parameter: 'Handle\_L1C\_QLT\_Mask' that must be set to 'TRUE' if the user wants to use the Quality Mask. This is set 'TRUE' by default since PB 04.00.

### 2.4.3 Metadata

Sen2Cor reads from the file GENERAL\_QUALITY.xml (that is present in the folder L1C\_product/GRANULE/tile\_id/QI\_DATA/) if loss of data is reported. In the affirmative case, it reads the list of the affected bands. Below, an example of a <check> from a GENERAL\_QUALITY.xml reporting data loss and affected bands.

```
<check>
  <inspection creation="2018-01-19T21:58:24.747Z" duration="276" execution="2018-01-19T21:58:24.762Z" id="Data_Loss"
  item="S2B_OPER_MSI_L1C_TL_MTI__20180119T211945_A004558_T07LEK_N02.06"
  itemURL="/dpc/data/phoebus-share/PHOEBUS-3.4.1/wp_in_progress/l1c_20180119_17/app_data/steps_data/L1C/TILE/S2B_OPER_MSI_L1C_TL_MTI__20180119T211945_A004558_T07LEK_N02.06/" name="Check TECQUA for data loss "
  priority="5" processingStatus="done" status="FAILED"/>
  <message contentType="text/plain">There is data loss in this tile.</message>
  <extraValues>
  <value name="Affected Bands">B06 B07 B08 B09 B10 B11 B8A</value>
  </extraValues>
</check>
```

### 2.4.4 Output Data

The generated mask will be visible in all the L2A \*.jp2 output (for example the \*\_TCI\_\*.jp2 file).

## 2.5 Product Generation

---

### 2.5.1 Input Data

All outputs from previous sections.



|   |  |  |
|---|--|--|
|  | <p><b>Optical MPC</b></p> <p><b>Sen2Cor 2.12.03 Input-Output Data Definition</b></p> | <p>Ref.: OMPC.TPZG.IOD.002<br/> Issue: 1.0<br/> Date: 10/09/2024<br/> Page: 34</p> |
|---|--|--|

## 2.5.2 Output Data

The generated output is dependent on the command line input as shown below. The output products itself are described and specified in detail in [S2-PDGS-MPC-L2A-PFS] and thus not repeated here.

### 2.5.2.1 Datastrip Generation

Command Line Parameter:

```
L2A_Process --mode=generate_datastrip --datastrip=L1C_DATASTRIP
            --output_dir=L2A_OUTPUT_DIR --work_dir=WORK_DIR --processing_centre=PROCESSING_CENTRE
            --archiving_centre=ARCHIVING_CENTRE --GIP_L2A_PB=GIP_L2A_PB (optional)
            --resolution=RESOLUTION (optional)
```

Generates a datastrip with optional processing baseline settings, which can be used as input for the next step of processing a single tile.

Input product should be in SAFE standard format. Output product will have the datastrip directory in SAFE standard format as well, all other components like metadata and reports will be generated in SAFE compact format.

### 2.5.2.2 Tile Generation

Command Line Parameter:

```
L2A_Process --mode=process_tile --datastrip=L2A_DATASTRIP --tile=L1C_TILE
            --output_dir=L2A_OUTPUT_DIR --work_dir=WORK_DIR --GIP_L2A_PB=GIP_L2A_PB (optional)
            --resolution=RESOLUTION (optional) --img_database_dir=IMG_DATABASE_DIR (optional)
            --res_database_dir=RES_DATABASE_DIR (optional)
```

Processes a tile with optional database locations and optional processing baseline settings, using a generated L2A datastrip as input. Database directories have been split into two different entities, one for the L1C image inputs, which will be kept in read only mode and a second database for the resampled auxiliary and intermediate products, which always will be overwritten and removed during the successive processing steps.

Input product should be in SAFE standard format. Output product will have the tile directory in SAFE standard format as well, all other components like metadata images and reports will be generated in SAFE compact format.

### 2.5.2.3 EUP Generation (Toolbox Mode)

Command Line Parameter:

```
L2A_Process input
usage: L2A_Process L1C_USER_PRODUCT --GIP_L2A_PB=GIP_L2A_PB (optional)
            --resolution=RESOLUTION (optional)
```

Processes an End User Product with optional processing baseline settings, using an L1C End User product of a given PSD as input. Input product should be V.14.(6-9), V.15 SAFE compact format. Output product will also be generated in SAFE compact format. Older products below PSD 14.6 will no longer be supported. Since Sen2Cor Version 2.10, Sen2Cor converts product below PSD 14.6 to PSD 14.6.

**2.5.2.4 Additional Output (since Sen2cor 2.11, PSD >= 14.9)**

Since Sen2cor 2.10 (PSD>=14.9), additional output comprises:

1- Additional L2A Quality parameters have been added to the already existing parameter in the L2A tile metadata in the 'Quality\_Indicator\_Info' section. These include:

- ❖ Cloudy\_pixel\_over\_land\_percentage;
- ❖ AOT\_retrieval\_method;
- ❖ Granule\_mean\_AOT;
- ❖ Granule\_mean\_wv;
- ❖ Ozone\_Source;
- ❖ Ozone\_Value.

2- Provision of the L2A Quality Report (see Figure 6): the new L2A\_Quality.xml report provides quality indicators information derived during the L2A process. They are separated in three main groups (that are subsequently divided into several subsections):

- ❖ Scene Class Quality Indicators;
- ❖ Atmospheric Correction Quality Indicators;
- ❖ Auxiliary Data Quality indicators.

A detailed description can be found at the end of the document in section 3.4.

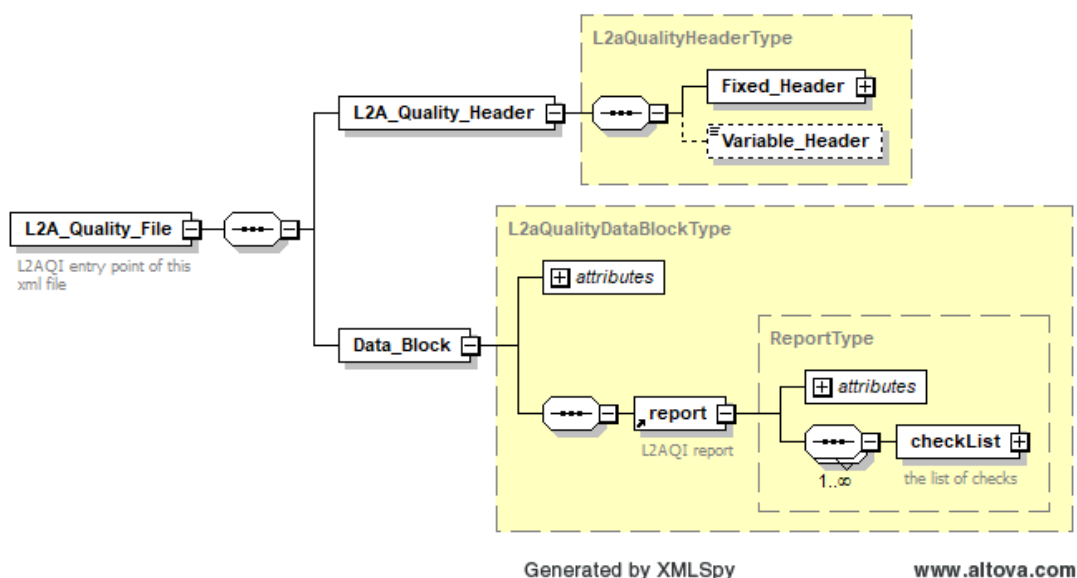

**Figure 6 – General schema of the new L2A\_Quality file**

|   |  |  |
|---|--|--|
|  | <h2 style="color: #0070C0;">Optical MPC</h2> <h3 style="color: #70AD47;">Sen2Cor 2.12.03 Input-Output Data Definition</h3> | <p>Ref.: OMPC.TPZG.IOD.002<br/> Issue: 1.0<br/> Date: 10/09/2024<br/> Page: 36</p> |
|---|--|--|

Note: Since Sen2Cor 2.12.01 and for products following PSD 15, the class <DARK\_FEATURES\_PERCENTAGE> is replaced by <CAST\_SHADOW\_PERCENTAGE>. Retro compatibility is maintained for product with PSD < 15.

Below an example of a L2A\_Quality file processed with Sen2Cor 2.12.03:

```
L2A_Quality_File xmlns:xsi="http://www.w3.org/2001/XMLSchema-instance" xmlns="http://gs2.esa.int/DATA_STRUCTURE/l2aqiReport"
xsi:schemaLocation="http://gs2.esa.int/DATA_STRUCTURE/l2aqiReport L2A_QUALITY.xsd">
<L2A_Quality_Header>
<Fixed_Header>
<File_Name>L2A_QUALITY</File_Name>
<File_Description>Quality information obtained from Sen2Cor</File_Description>
<Notes/>
<Mission>S2A</Mission>
<!-- This can be set to OPER or USER dependent on PDGS or Toolbox mode -->
<File_Class>USER</File_Class>
<File_Type>L2A_QUINFO</File_Type>
<Validity_Period>
<Validity_Start>UTC=2015-06-22T00:00:00</Validity_Start>
<Validity_Stop>UTC=2100-01-01T00:00:00</Validity_Stop>
</Validity_Period>
<File_Version>1</File_Version>
<Source>
<System>Sen2Cor</System>
<Creator>Sen2Cor</Creator>
<Creator_Version>2.10</Creator_Version>
<Creation_Date>UTC=2024-08-20T11:48:52</Creation_Date>
</Source>
</Fixed_Header>
</L2A_Quality_Header>
<Data_Block type="xml">
<report gippVersion="02.12.03" globalStatus="PASSED" date="2024-08-02T00:00:00Z">
<checkList>
<parentID>L2A_SC</parentID>
<name>SCENE_CLASS_QUALITY</name>
<version>2.10</version>
<item class="http://www.esa.int/s2#pdi_level_2a_tile_container" className="PDI Level 2A Tile Folder"
name="L2A_T33TXF_A047795_20240816T094857" url="/Users/.../.../.../
/S2A_MSIL2A_20240816T094031_N9999_R036_T33TXF_20240820T113603.SAFE/GRANULE/L2A_T33TXF_A047795_20240816T094857/AUX_D
ATA"/>
<check>
<message contentType="text/plain">"Percentage of classified pixels"</message>
<extraValues>
<value name="CLOUDY_PIXEL_PERCENTAGE">0.063656</value>
<value name="CLOUDY_PIXEL_OVER_LAND_PERCENTAGE">0.081099</value>
<value name="DEGRADED_MSI_DATA_PERCENTAGE">0.000000</value>
<value name="NODATA_PIXEL_PERCENTAGE">0.000000</value>
<value name="SATURATED_DEFECTIVE_PIXEL_PERCENTAGE">0.000000</value>
<value name="CAST_SHADOW_PERCENTAGE">0.001868</value>
<value name="CLOUD_SHADOW_PERCENTAGE">0.043517</value>
<value name="VEGETATION_PERCENTAGE">8.204521</value>
<value name="NOT_VEGETATED_PERCENTAGE">50.011075</value>
<value name="WATER_PERCENTAGE">41.667086</value>
<value name="UNCLASSIFIED_PERCENTAGE">0.008281</value>
<value name="MEDIUM_PROBA_CLOUDS_PERCENTAGE">0.043139</value>
<value name="HIGH_PROBA_CLOUDS_PERCENTAGE">0.020053</value>
<value name="THIN_CIRRUS_PERCENTAGE">0.000464</value>

```

```

<value name="SNOW_ICE_PERCENTAGE">0.000000</value>
</extraValues>
</check>
</checkList>
<checkList>
<parentID>L2A_AC</parentID>
<name>ATMOSPHERIC_CORRECTION_QUALITY</name>
<version>2.10</version>
<item class="http://www.esa.int/s2#pdi_level_2a_tile_container" className="PDI Level 2A Tile Folder"
name="L2A_T33TXF_A047795_20240816T094857"
url="/Users/.../.../.../S2A_MSIL2A_20240816T094031_N9999_R036_T33TXF_20240820T113603.SAFE/GRANULE/L2A_T33TXF_A047795_2024
0816T094857/AUX_DATA"/>
<check>
<message contentType="text/plain">Atmospheric correction quality values</message>
<extraValues>
<value name="AOT_RETRIEVAL_ACCURACY">0.000000</value>
<value name="GRANULE_MEAN_AOT">0.216586</value>
<value name="WV_RETRIEVAL_ACCURACY">0.000000</value>
<value name="GRANULE_MEAN_WV">2.562026</value>
<value name="OZONE_VALUE">294.645253</value>
<value name="START_VISIBILITY_KM">40.000000</value>
<value name="VISIBILITY_FROM_DDV_KM">35.690000</value>
<value name="FINAL_VISIBILITY_KM">35.690000</value>
<value name="AVERAGE_SOLAR_ZENITH_ANGLE">31.222794</value>
<value name="DDV_PIXEL_PERCENTAGE">2.590778</value>
<value name="DDV_REFLECTANCE_RANGE">0.120000</value>
<value name="BLUE_PATH_RADIANCE_RESCALING_FACTOR">1.000000</value>
</extraValues>
</check>
<check>
<message contentType="text/plain">Atmospheric correction quality control</message>
<extraValues>
<value name="AC_ENABLED">True</value>
<!-- WV_RETRIEVAL_METHOD: SEN2COR_APDA | NA -->
<value name="WV_RETRIEVAL_METHOD">SEN2COR_APDA</value>
<!-- AOT_RETRIEVAL_METHOD: SEN2COR_DDV | CAMS | DEFAULT | NA -->
<value name="AOT_RETRIEVAL_METHOD">SEN2COR_DDV</value>
<value name="VISIBILITY_LESS_THAN_5_KM">False</value>
<value name="AOT_ABOVE_1">False</value>
<value name="GRANULE_WV_ABOVE_5_CM">False</value>
</extraValues>
</check>
<check>
<message contentType="text/plain">Percentage of negative BOA pixels</message>
<extraValues>
<value name="B01">0.062253</value>
<value name="B02">0.007518</value>
<value name="B03">0.000703</value>
<value name="B04">0.000056</value>
<value name="B05">0.000461</value>
<value name="B06">0.004711</value>
<value name="B07">0.002618</value>
<value name="B08">0.001705</value>
<value name="B8A">0.178453</value>
<value name="B11">0.000033</value>
<value name="B12">0.000000</value>
</extraValues>
</check>
<check>
<message contentType="text/plain">Look up table file list</message>

```

```

<extraValues>
<value name="LUT_DATA_FILES">['g99000_wv20_rura.atm']</value>
</extraValues>
</check>
</checkList>
<checkList>
<parentID>L2A_AUX</parentID>
<name>AUX_DATA_QUALITY</name>
<version>2.10</version>
<item class="http://www.esa.int/s2#pdi_level_2a_tile_container" className="PDI Level 2A Tile Folder"
name="L2A_T33TXF_A047795_20240816T094857" url="/Users/.../.../.../
/S2A_MSIL2A_20240816T094031_N9999_R036_T33TXF_20240820T113603.SAFE/GRANULE/L2A_T33TXF_A047795_20240816T094857/AUX_D
ATA"/>
<check>
<message contentType="text/plain">AUX related parameters</message>
<extraValues>
<!-- DEM_TYPE: SRTM_90 | DTED_90 | DTED_30 | (CDSE-AWS) COPERNICUS_90 | (CDSE-AWS) COPERNICUS_30 -->
<value name="DEM_TYPE">CDSE_COPERNICUS_90</value>
<value name="DEM_MEAN_ALTITUDE_KM">0.28361502</value>
<value name="DEM_MEAN_SLOPE">2.962581</value>
<value name="GROUND_ELEVATION_ABOVE_3_KM">False</value>
<value name="SOLAR_ZENITH_ANGLE_ABOVE_70_DEG">False</value>
<!-- OZONE_SOURCE: AUX_ECMWFT | CONFIG | OTHER -->
<value name="OZONE_SOURCE">AUX_ECMWFT</value>
</extraValues>
</check>
<check>
<message contentType="text/plain">AUX data file list</message>
<extraValues>
<value name="AUX_DATA_FILES">['Copernicus_DSM_30_N40_00_E016_00_DEM.tif', 'Copernicus_DSM_30_N41_00_E016_00_DEM.tif',
'Copernicus_DSM_30_N40_00_E017_00_DEM.tif', 'Copernicus_DSM_30_N41_00_E017_00_DEM.tif']</value>
</extraValues>
</check>
</checkList>
</report>
</Data_Block>
</L2A_Quality_File>

```

## 3 GIPP Additional Settings

### 3.1 Expert Parameters for Scene Classification

The default expert parameters for the Scene Classification are located in a file named L2A\_CAL\_SC\_GIPP.xml, located in the cfg folder of the sen2cor subdirectory within the Sen2Cor package. They can be overwritten with an external configuration referred to via command line (see section 2.1.7).

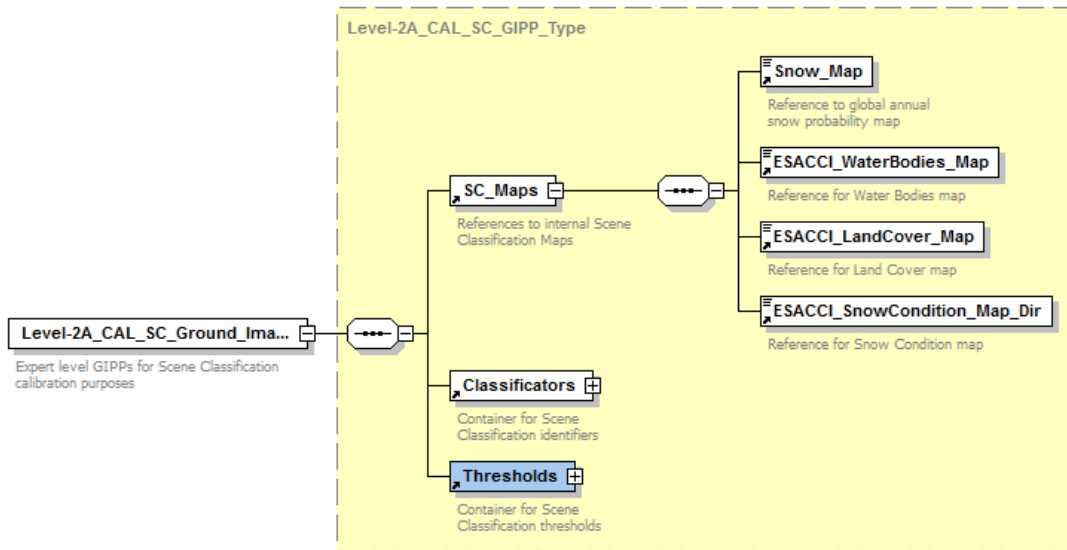

**Figure 7 – Processing Baseline GIPP**

For a full list of all types, parameters, and default values, please consult the embedded PDF in section 3.4.

### 3.2 Expert Parameters for Atmospheric Correction

The default expert parameters for the Atmospheric Correction are in a file named L2A\_CAL\_AC\_GIPP.xml, located in the cfg folder of the sen2cor subdirectory within the Sen2Cor package. They can be overwritten with an external configuration referred to via command line (see section 2.1.7).

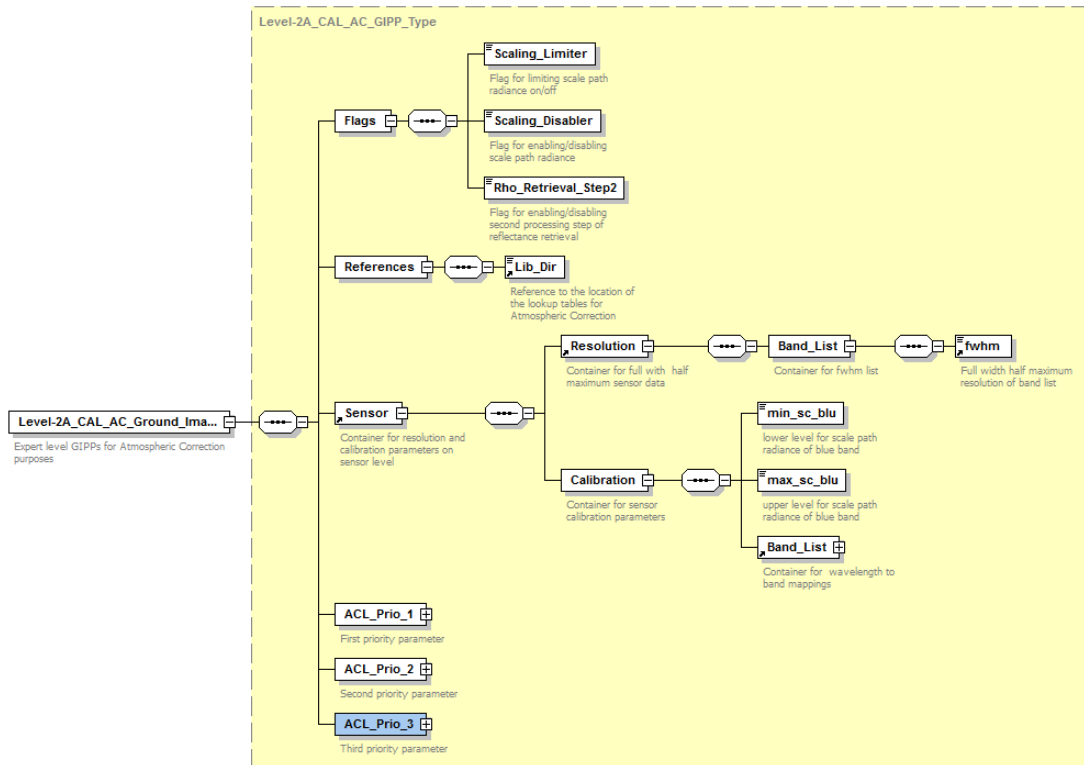

Figure 8 – Processing Baseline GIPP

For a full list of all types, parameters and default values, consult the embedded GIPP PDF in Section 3.4.

### 3.3 Processing Baseline Parameters

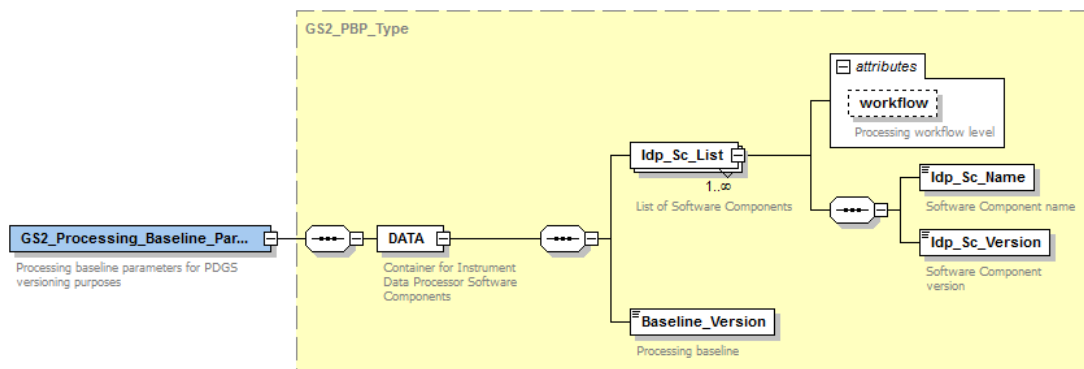

Figure 9 – Processing Baseline GIPP

*Table 3-1 – Processing Baseline GIPP*

| <b>Field Name / Attribute</b> | <b>Documentation</b>  | <b>Type</b> |
|-------------------------------|---|-------------|
| DATA                          | Container for Instrument Data Processor Software Components | Complex     |
| IDp_Sc_List                   | List of Software Components                                 | Complex     |
| workflow                      | Processing workflow level                                   | String      |
| IDp_Sc_Name                   | Software Component name                                     | String      |
| IDp_Sc_Version                | Software Component version                                  | String      |
| Baseline_Version              | Processing baseline   | Double      |

Adding an optional xml input in the format of a processing baseline allows overwriting the corresponding fields in the metadata and filenames.

For a full list of all types, parameters, and default values, please consult the embedded PDF in section 3.4.

### 3.4 Additional Documentation

---

The full reference of all GIPPs is contained in the embedded PDF documents. GIPPs from Sen2Cor 2.12.03 are embedded considering the release and implementation of PSD 15.