





S2 MPC

Level 2A Input Output Data Definition

Ref. S2-PDGS-MPC-L2A-IODD-2.10



Authors Table

	Name	Company	Responsibility	Date	Signature
Written by	F.C. Pignatale	TPZG	Sen2Cor Maintenance	2021-12-13	
Verified by	O Devignot	CS	Quality Manager	2021-12-13	
Approved by	L. Pessiot	CS	Service Manager	2021-12-13	

Change Log

Issue	Date	Reason for change	Pages(s)/Section(s)
1.0	2014-03-27	Creation	
2.3	2016-11-25	Update for Sen2Cor V.2.3.0	All pages
2.4	2017-07-18	Update for Sen2Cor V.2.4.0	All pages
2.6	2018-02-23	Updates for Sen2Cor V.2.6.1: Updated all GIPP Schemes and description Resolved RIDS from TAS as listed below	See attached PDF in section 3.4
		Fig.6: This figure indicates a GML-JPEG2000 format for the images (understood as a GML geotag in JPEG2000 header) while table 25 indicates only JPEG2000. Please clarify.	Fig. 6 removed and Table updated. Section 2.5.2 contains a reference to [S2-PDGS-MPC-L2A-PFS], which contains the specification of the image formats
		Section Atmospheric Correction and Scene Classification : with GIPP AC and SC provided through expert level, please confirm the Sen2Cor ignore the Atmospheric_Correction and Scene_Classification tags in the \$SEN2COR_HOME/cfg/L2A_GIPP.xml	Sections 3.1, 3.2 updated to contain the necessary information
		The GIP_L2A_PB does not seem to be described	Section 3.3 inserted to contain the necessary information
		Added section on Auxiliary Data for Scene Classification	Section 2.2.5
		Updated Ozone Content GIPP according to review comments, J. Louis	Section 2.2.3

Issue	Date	Reason for change	Pages(s)/Section(s)
2.7	2018-09-21	Updates for Sen2Cor V.2.7.0: added GIPPs for Database compression factor and disabling of terrain correction with DEM. Added further command line parameters for determining database location.	Sections 2.1.2, 2.1.6
2.8	2019-01-29	Updates for Sen2Cor V.2.8.0: removed parameter Nr_Processes and added parameters Nr_Treads and Ac_Dem_P2p_Val	Section 2.1.2 and 3.4
2.9	2020-07-01	Updates for Sen2Cor V.2.9.0: added parameters for Section Region_Of_Interest and Force_Exit_On_DEM_Errors	Section 2.1.2 and 3.4
2.10	2021-12-13	Updates for Sen2Cor V.2.10: updated with all the new input and output information from PSD-14.9 and Evolutionary Upgrades.	Section 1, 2, 3

Table of contents

1. INTRODUCTION	8
1.1 Purpose of the document	8
1.2 Document Structure	8
1.3 References	8
2. LEVEL-2A PRODUCTS OVERVIEW	11
2.1 Common Data	11
2.1.1 Input Data	11
2.1.2 GIPP	13
2.1.3 Metadata	18
2.1.4 Auxiliary Data	19
2.1.5 QI Data	20
2.1.6 Output Data	20
2.1.7 Command Line Parameters	21
2.2 Scene Classification	22
2.2.1 Input Data	22
2.2.2 GIPP	22
2.2.2.1 Expert Level	22
2.2.3 Metadata	22
2.2.4 Cython Library	23
2.2.5 Auxiliary Data	23
2.2.6 Output Data	26
2.3 Atmospheric Correction	28
2.3.1 Input Data	28
2.3.2 GIPP	28
2.3.2.1 Expert Level	30
2.3.3 Metadata	30
2.3.4 Auxiliary Data (Look Up Tables)	30
2.3.5 Output Data	33
2.3.6 Aerosol Optical Thickness Retrieval	33
2.3.6.1 Input Data	34
2.3.6.2 GIPP	34
2.3.6.3 Metadata	34
2.3.6.4 Output Data	35
2.3.7 Water Vapour Retrieval	35
2.3.7.1 Input Data	35
2.3.7.2 GIPP	36
2.3.7.3 Metadata	36
2.3.7.4 Output Data	36
2.3.8 Cirrus Correction	37
2.3.8.1 Input Data	37
2.3.8.2 GIPP	37

2.3.8.3	Metadata	37
2.3.8.4	Output Data	37
2.3.9	Terrain Correction	37
2.3.9.1	Input Data	37
2.3.9.2	GIPP	37
2.3.9.3	Metadata	39
2.3.9.4	Output Data	39
2.3.10	Surface Reflectance.....	39
2.3.10.1	Input Data	39
2.3.10.2	GIPP	39
2.3.10.3	Metadata	39
2.3.10.4	Output Data	40
2.4	Quality Mask	43
2.4.1	Input Data	43
2.4.2	GIPP.....	43
2.4.3	Metadata	43
2.4.4	Output Data	43
2.5	Product Generation.....	43
2.5.1	Input Data	43
2.5.2	Output Data	44
2.5.2.1	Datastrip Generation	44
2.5.2.2	Tile Generation	44
2.5.2.3	EUP Generation (Toolbox Mode).....	44
2.5.2.4	Additional Output (Sen2cor 2.10, PSD >= 14.9)	44
3.	GIPP ADDITIONAL SETTINGS	49
3.1	Expert Parameters for Scene Classification.....	49
3.2	Expert Parameters for Atmospheric Correction.....	49
3.3	Processing Baseline Parameters	50
3.4	Additional Documentation	51

List of Figures

Figure 1 – GIPP of Common Section	14
Figure 2 – GIPP of Scene Classification	22
Figure 3 – QI Data of Tile and User Product Metadata.....	25
Figure 4 – GIPP for Atmospheric Correction Module.....	28
Figure 5– GIPP for selection of Look_Up_Tables.....	34
Figure 6: General schema of the new L2A_Quality file	45
Figure 7 – Processing Baseline GIPP.....	49
Figure 8 – Processing Baseline GIPP.....	50
Figure 9 – Processing Baseline GIPP.....	50

List of Tables

Table 2-1 – L1C Image data specification	11
Table 2-2 – Common GIPP.....	15
Table 2-3 – Metadata input fields (see L2A-PFS for details).....	18
Table 2-4 – Aux_Data	19
Table 2-5 – QI_Data	20
Table 2-6: Command Line Parameters.....	21
Table 2-7 – GIPP of Scene Classification	22
Table 2-8 – Cloud Probability map	26
Table 2-9 – Snow Probability map.....	26
Table 2-10 – Scene Classification.....	27
Table 2-11 – GIPP for selection of Look_Up_Tables	29
Table 2-12 – Parameter space for atmospheric correction	30
Table 2-13 – LUT file naming conventions.....	31
Table 2-14 – Structure and format of the atmospheric LUT files.....	32
Table 2-15 – Column structure of atmospheric LUT files	33
Table 2-16 – Band subsets.....	34
Table 2-17 – CAMS auxiliary input	34
Table 2-18 – Aerosol Optical Thickness (AOT) map	35
Table 2-19 – WVP columns	35
Table 2-20 – Band subsets.....	35
Table 2-21 – GIPP input fields	36
Table 2-22 – Water Vapour Map	36
Table 2-23 – Band subset	37
Table 2-24 – Inputs parameter cirrus correction	37
Table 2-25 – GIPP terrain correction	37
Table 2-26 – GIPP surface reflectance	39
Table 2-27 – Outputs surface reflectance.....	40
Table 3-1 – Processing Baseline GIPP	51

This Page Is Intentionally Blank

1. Introduction

1.1 Purpose of the document

This Document lists the Input Output Data Definitions of the Sen2Cor application. This Document is updated with the evolutions present in the Sen2Cor 2.10 version.

1.2 Document Structure

This document includes new dedicated sections with all the input and output related to the evolutions implemented in Sen2Cor 2.10. Furthermore, this IODD lists for each of the following processes:

- Scene Classification;
- Atmospheric Correction, with sub-processes:
 - Aerosol Optical Thickness Retrieval;
 - Water Vapour retrieval;
 - Cirrus Correction;
 - Terrain Correction;
 - Surface Reflectance;
- Quality Masks;

The corresponding Input and Output data separated according the following four criteria (when applicable):

- Input Data;
- Ground Image Processing Parameter (GIPP);
- Metadata;
- Output Data.

1.3 References

Document ID	Description	Version
S2-PDGS-MPC-L2A-PFS	Sentinel-2 MSI – Product Format Specification	14.6
S2-PDGS-MPC-L2A-PFS	Sentinel-2 MSI – Product Format Specification	14.9
S2-PDGS-MPC-L2A-SUM	Sentinel-2 MSI – Level 2A Prototype Processor Installation and User Manual	2.10
S2-PDGS-MPC-L2A-ATBD	Sentinel-2 MSI - Level 2A Products, Algorithm Theoretical Basis Document	2.10
S2-PDD	GMES Space Component – Sentinel-2 Payload Data Ground Segment (PDGS), Product Definition Document	14.9_4.9

Document ID	Description	Version
S2-PSD	Sentinel-2 Products Specification Document	14.6
S2-PSD	Sentinel-2 Products Specification Document	14.9

This Page Is Intentionally Blank

2. Level-2A Products Overview

2.1 Common Data

This section lists all IO data and parameters that are related to the basic operation of the processor.

2.1.1 Input Data

The input data on pixel level and the L1C product formats are described in detail in [L2A-PFS], see also Table 2-1.

Table 2-1 – L1C Image data specification

Name	Level-1C
Parent Product	L1C, TOA Reflectance
Coverage	Regional
Packaging	Tiles (same area coverage as Level 1C input data)
Geo-location accuracy	Identical to the level 1C geo-location performance
Frequency	Variable upon Level 1C products availability

Name	Level-1C
Format	<p>Kakadu 7.4, details @60 m processing:</p> <p>Codestream, import Band1, 60m res:</p> <ul style="list-style-type: none"> SOC marker segment @ (1927, 0) SIZ marker segment @ (1929, 41) Profile: no profile Reference Grid Height, Width: (1830 x 1830) Vertical, Horizontal Reference Grid Offset: (0 x 0) Reference Tile Height, Width: (192 x 192) Vertical, Horizontal Reference Tile Offset: (0 x 0) Bitdepth: (15,) Signed: (False,) Vertical, Horizontal Subsampling: ((1, 1),) COD marker segment @ (1972, 17) Coding style: <ul style="list-style-type: none"> Entropy coder, with partitions SOP marker segments: False EPH marker segments: False Coding style parameters: <ul style="list-style-type: none"> Progression order: LRCP Number of layers: 1 Multiple component transformation usage: no transform specified Number of resolutions: 5 Code block height, width: (4 x 4) Wavelet transform: 5-3 reversible Precinct size: ((64, 64),(64, 64),(64, 64),(64, 64),(64, 64)) Code block context: <ul style="list-style-type: none"> Selective arithmetic coding bypass: False Reset context probabilities on coding pass boundaries: False Termination on each coding pass: False Vertically stripe causal context: False Predictable termination: False Segmentation symbols: False QCD marker segment @ (1991, 16) Quantization style: no quantization, 1 guard bits Step size: [(0, 16), (0, 17), (0, 17), (0, 18), (0, 17), (0, 17), (0, 18), (0, 17), (0, 17), (0, 17), (0, 16), (0, 16), (0, 17)] CME marker segment @ (2009, 15) "Kakadu-v7.4" CME marker segment @ (2026, 92) "Kdu-Layer-Info: log₂{Delta-D(squared-error)/Delta-L(bytes)}, L(bytes) -192.0, 3.8e+06"

Name	Level-1C
Unit	Dimensionless, Unsigned Integer 15 bit
Calibration and Range	1 / 10000: i.e.: Digital Numbers 0 : 10000, representing radiometric reflectance values from 0.0 to 1.0
Sampling	16 bit/pixel
Channels and Resolution	Resolution (m)
B1 (443nm)	60
B2 (490nm)	10
B3 (560nm)	10
B4 (665nm)	10
B5 (705nm)	20
B6 (740nm)	20
B7 (783nm)	20
B8 (842nm)	10
B8a (865nm)	20
B9 (945nm)	60
B10 (1375)	60
B11 (1610nm)	20
B12 (2190nm)	20

2.1.2 GIPP

GIPPs are configured in an XML file named L2A_GIPP.xml, located in the <cfg> subdirectory of the Sen2Cor home directory which is specified by the environment variable \$SEN2COR_HOME, and can be configured by the user. Exceptions, which should not be configured by standard users, are marked with an asterisk (*).

The file is subsequently copied into the AUX_DATA subfolder of the corresponding granule for documentation purposes.

Within this IODD the GIPP are listed within their current processing context. Figure 1 and Table 2-2 show and describe the GIPP, which are common for the overall

processing. Specific GIPPs are listed in the corresponding subsections separated for each sub-processing step.

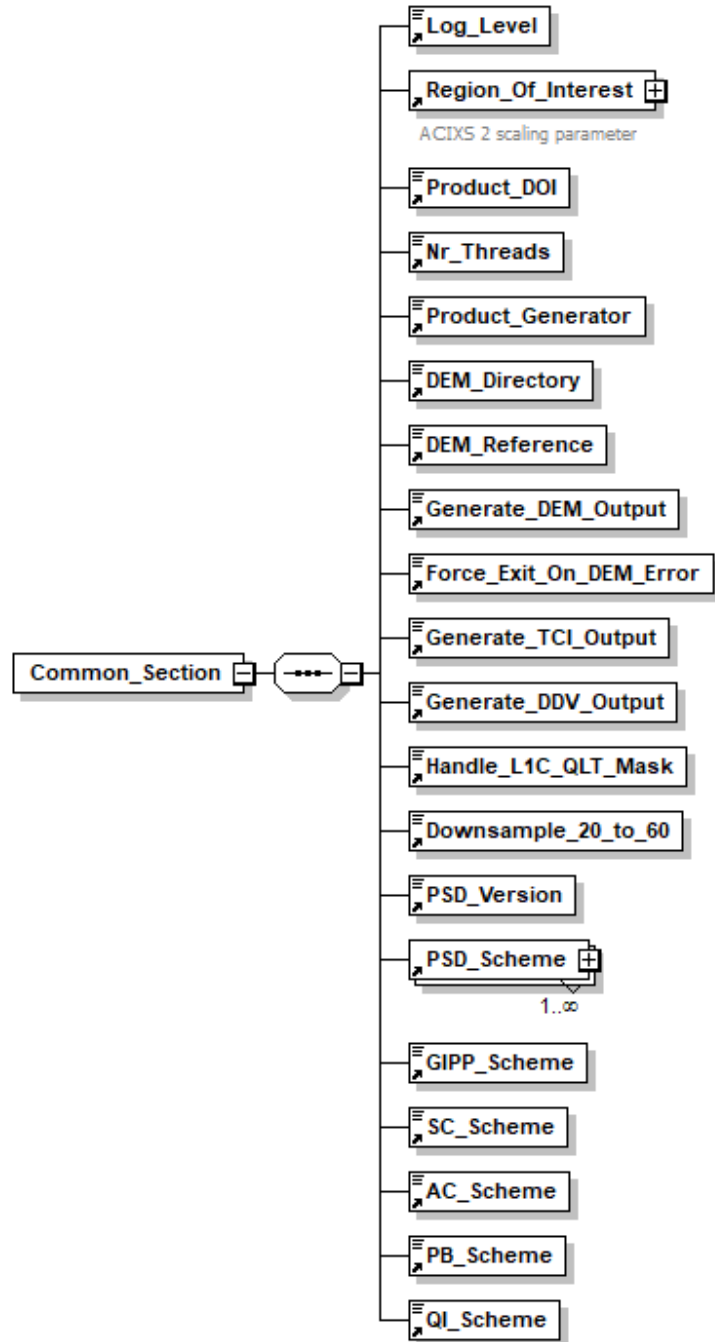

Generated by XMLSpy

www.altova.com

Figure 1 – GIPP of Common Section

Table 2-2 – Common GIPP

Field Name	Documentation	Type
Log_Level	Verbosity level of the tracing output, located in the GRANULE/<GRANULE>/QI_DAT A folder.	Enumerator: NOTSET, DEBUG, INFO, WARNING, ERROR, CRITICAL
Region_Of_Interest	<p>This section has been established with release 2.9.0. It contains four parameters which define a configurable Region of Interest (ROI):</p> <ul style="list-style-type: none"> row0 col0 nrow_win ncol_win <p>row0, col0, nrow_win and ncol_win must be integer divisible by 6, to prevent rounding errors for downsampling. See SUM for Details.</p>	<p>Choice: Off, AUTO or: Unsigned Integer Values [0:10979]</p> <p>if row0 == OFF: a standard processing without ROI detection is performed;</p> <p>if row0 == AUTO: a region of interest is detected automatically via an algorithm;</p> <p>Else: row0, col0: specify the midpoint of the region of interest, nrow_win, ncol_win define a rectangle around the midpoint within a frame of 10980 x 10989 pixel</p>
Product DOI (Sen2Cor 2.10)	DOI: Digital Object Identifier. This Object identifier is implemented for Sen2Cor 2.10 for PSD Versions 14.7 and above. The URL shall be inserted as a configuration item in this entry	URL
Nr_Threads	This parameter allowing the usage of multithreading to speed up the reading of the L1C input images. above). It is set to AUTO by default, which detects the amount of usable threads by calling cpu_count(). If the user does not want this feature or want to set the amount of threads individually, the parameter can be changed between a value of 1 (which is single thread processing, as before) up to 8.	Choice: AUTO or: Unsigned Integer Value [1:8]

Field Name	Documentation	Type
Product Generator (Sen2Cor 2.10)	This parameter foresees the usage of the PDGS PSD converter in the toolbox mode. Not implemented in v.2.10	Choice: Directory where the converter is located or 'NONE'
DEM_Directory	Location of optional Digital Elevation Map: can be either a directory in the sen2cor home folder or 'NONE'. If NONE, no DEM will be used. Example: 'dem/srtm'. DEM will be searched in: <SEN2COR_HOME>/dem/srtm	Choice: NONE or String (relative directory path)
DEM_Reference	If no suitable DEM is found in the DEM directory, the processor tries to download a DEM from the given reference. -Sen2Cor 2.10 now supports the Copernicus DEM, downloadable form: -The link will be provided within a dedicated news on STEP. This document will be then updated- -SRTM the freely available CGIAR 90 m resolution DEM, which can be downloaded from: http://data_public:GDdci@data.cgiar-csi.org/srtm/tiles/GeoTIFF https://srtm.csi.cgiar.org/disclaimer/	URL
Generate_DEM_Output	FALSE: no DEM output, TRUE: store DEM in the AUX data directory	FALSE or TRUE
Force_Exit_On_DEM_Error	This parameter has been established with release 2.9.0: if set to FALSE, processing continues with a flat surface, if a DEM is not found or cannot be downloaded. If set to TRUE, processing will be stopped.	FALSE or TRUE
Generate_TCI_Output	FALSE: no TCI output, TRUE: store TCI in the IMAGE data directory	FALSE or TRUE

Field Name	Documentation	Type
Generate_DDV_Output	FALSE: no DDV output, TRUE: store DDV in the QI_DATA directory	FALSE or TRUE
Handle_L1C_QLT_Mask (Sen2Cor 2.10)	FALSE: no handling of the L1C Quality Mask. TRUE: handling L1C Quality Mask	FALSE or TRUE
Downsample_20_to_60	TRUE: create additional 60m bands when 20m is processed	FALSE or TRUE
PSD_Version (Sen2Cor 2.10.01)	Special entry for forcing a special PSD version to be processed. DEFAULT: automatic detection of the PSD version.	DEFAULT or PSD version
PSD_Scheme (*)	<p>List of supported PSD Versions: V 14.2 – V.14.6 (Sen2Cor 2.9.0) V 14.9 (Sen2Cor 2.10)</p> <p><u>Properties:</u></p> <ul style="list-style-type: none"> • Version: The PSD Versions • PSD_Reference: the names of the available PSD schemes <p><u>Names:</u> UP_Scheme_1C: <name> UP_Scheme_2A: <name> Tile_Scheme_1C <name> Tile_Scheme_2A <name> DS_Scheme_1C: <name> DS_Scheme_2A: <name></p> <p><u>Remark:</u> these schemes are used for validation of the in- and output metadata. The configuration should not be changed by the user</p>	XML List of strings
GIPP_Scheme (*)	Name of the xsd scheme for the base GIPP (this file, used for validation purposes)	String (filename). Default is L2A_GIPP
SC_Scheme (*)	Name of the xsd scheme for the expert calibration GIPP for scene classification (used for validation purposes, not foreseen to be configured by standard uses).	String (filename). Default is: L2A_CAL_SC_GIPP

Field Name	Documentation	Type
AC_Scheme (*)	Name of the xsd scheme for the expert calibration GIPP for the atmospheric correction (used for validation purposes, not foreseen to be configured by standard uses).	String (filename). Default is:L2A_CAL_AC_GIPP
PB_Scheme (*)	Name of the xsd scheme for the Processing Baseline.	String (filename). Default is:L2A_PB-_GIPP
QI_Scheme(*) (Sen2Cor 2.10.01)	Name of the xsd scheme for the L2A_Quality report	String (filename). Default is:L2A_QUALITY

For a full list of all types, parameters and default values, consult the embedded PDF in the 3.4.

2.1.3 Metadata

Metadata (Table 2-3) are read out directly from the Level 2A Tile metadata XML file after being generated from the corresponding Level-1C User product.

Table 2-3 – Metadata input fields (see L2A-PFS for details)

Field Name	Documentation	Type
ZENITH_ANGLE	Incidence angles	Floating point 32 bit
AZIMUTH_ANGLE	Incidence angles	Floating point 32 bit
Zenith	Grids for Zenith Viewing Incidence Angle values (0 - 70°)	Floating point array 32 bit
Azimuth	Grids for Azimuth Viewing Incidence Angle values (0 – 360°)	Floating point array 32 bit
QUANTIFICATION_VALUE	Digital Number of L1C Input bands, dimensionless, 0 :10.000 corresponds to TOA reflectance 0 : 1	Unsigned Integer
ECMWF_DATA_REFERENCE	Filename of the ECMWF data located in the GRANULE/AUX_DATA folder	String (filename)

Field Name	Documentation	Type
Radiometric_Offset_List (Sen2Cor 2.10)	List of band dependent radiometric offset	Integer

2.1.4 Auxiliary Data

Table 2-4 – Aux_Data

Field Name	Documentation	Type
DEM	Digital Elevation Map, user configurable image data located in \$SEN2COR_HOME, directory, configurable via L2A_GIPP, see Table 2 – Common GIPP Unit: m	Tiff or Dted format (dt1) Integer, 16 bit As OpenJPEG is only able to store unsigned integer values, an offset of +10.000 is applied to each DEM allowing negative heights. The scale of the DEM is thus (meter – 10.000).
AUX_ECMWF, located in the GRANULE/AUX_DATA folder	Raster data of Block Size 9:9 in GRIB Format, 6 Bands, specifying: B1: Precipitable water content [kg/m ²] B2: Mean sea level pressure [Pa] B3: Total column ozone Dobson [kg/m ²] B4: 10m U wind component [m/s] B5: 10m V wind component [m/s] B6: Relative humidity [%]	Float 64

Field Name	Documentation	Type
AUX_CAMSxx (Sen2Cor 2.10)	Raster data of Block Size 9:9 in GRIB Format, 11 bands of which the following are used: -Total Aerosol Optical Depth at 550nm (aod550); - Surface Geopotential (z)	Float 64

2.1.5 QI Data

Table 2-5 – QI_Data

Field Name	Documentation	Type
MSK_QUALIT_BXX (Sen2Cor 2.10)	List of band-depended quality masks to populate the L2A SCL defective pixel class.	Integer (0,1)

2.1.6 Output Data

Outputs are classified specifically for the corresponding procedures in the equivalent sections for the sub modules.

2.1.7 Command Line Parameters

In the following Table 2-6, the list of the command line parameters can be found. Lists are provided for both the PDGS and Toolbox modes.

Table 2-6: Command Line Parameters

Command Line Parameters ("Toolbox" mode. L1C product as input_dir)	
L2A_Process --help	
usage: L2A_Process.py [-h] [--mode MODE] [--resolution {10,20,60}]	
	[--datastrip DATASTRIP] [--tile TILE]
	[--output_dir OUTPUT_DIR] [--work_dir WORK_DIR]
	[--img_database_dir IMG_DATABASE_DIR]
	[--res_database_dir RES_DATABASE_DIR]
	[--processing_centre PROCESSING_CENTRE]
	[--archiving_centre ARCHIVING_CENTRE]
	[--processing_baseline PROCESSING_BASELINE] [--raw]
	[--tif] [--sc_only] [--sc_classic] [--sc_cog]
	[--cr_only] [--debug] [--GIP_L2A GIP_L2A]
	[--GIP_L2A_SC GIP_L2A_SC] [--GIP_L2A_AC GIP_L2A_AC]
	[--GIP_L2A_PB GIP_L2A_PB]
	input_dir
Sen2Cor. Version: 2.10.0, created: 2021.10.12, supporting Level-1C product version 14.2 - 14.9.	
positional arguments:	
input_dir	Directory of Level-1C input
optional arguments:	
-h, --help	show this help message and exit
--mode MODE	Mode: generate_datastrip, process_tile
--resolution {10,20,60}	Target resolution, can be 10, 20 or 60m. If omitted, only 20 and 10m resolutions will be processed
--datastrip DATASTRIP	Datastrip folder
--tile TILE	Tile folder
--output_dir OUTPUT_DIR	Output directory
--work_dir WORK_DIR	Work directory
--img_database_dir IMG_DATABASE_DIR	Database directory for L1C input images
--res_database_dir RES_DATABASE_DIR	Database directory for results and temporary products
--processing_centre PROCESSING_CENTRE	Processing centre as regex: ^[A-Z_]{4}\$, e.g "SGS_"
--archiving_centre ARCHIVING_CENTRE	Archiving centre as regex: ^[A-Z_]{4}\$, e.g. "SGS_"
--processing_baseline PROCESSING_BASELINE	Processing baseline in the format: "dd.dd", where d=[0:9]
--raw	Export raw images in rawl format with ENVI hdr
--tif	Export raw images in TIFF format instead of JPEG-2000
--sc_only	Performs only the scene classification at 60 or 20m resolution
--sc_classic	Performs scene classification in Sen2Cor 2.9 mode
--sc_cog	Export SCL image in COG format instead of JPEG_2000
--cr_only	Performs only the creation of the L2A product tree, no processing
--debug	Performs in debug mode
--GIP_L2A GIP_L2A	Select the user GIPP
--GIP_L2A_SC GIP_L2A_SC	Select the scene classification GIPP
--GIP_L2A_AC GIP_L2A_AC	Select the atmospheric correction GIPP
--GIP_L2A_PB GIP_L2A_PB	Select the processing baseline GIPP

2.2 Scene Classification

2.2.1 Input Data

L1C Image data as specified in Section 2.1.1, resampled to the requested resolution of 60, 20, 10 m.

2.2.2 GIPP

Figure 2 shows the GIPP of the Scene Classification Module, while Table 2-7 describes the related input.

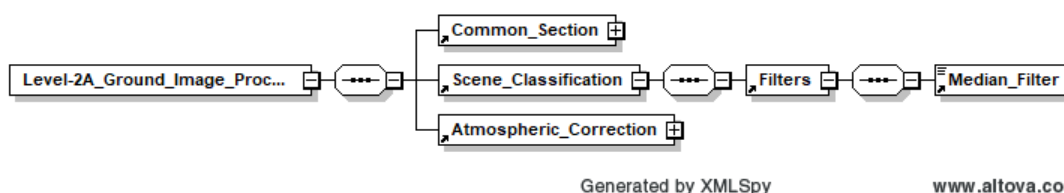

Figure 2 – GIPP of Scene Classification

For a full list of all types, parameters and default values, consult the embedded PDF in 3.4. With Sen2Cor 2.10 the improved Scene Classification Evolution is used as default. User can switch to the classic algorithm by the command line – sc_classic. From Sen2Cor 2.10, the dedicated optional command line (--sc_cog) saves the Scene Classification output in COG (Cloud Optimized Geotiff) format.

Table 2-7 – GIPP of Scene Classification

Field Name	Documentation	Type
Median_Filter	Digital Filter for smoothing of Classification map.	Unsigned Integer, recommended values 0:3, Default: 0

2.2.2.1 Expert Level

GIPP for the Scene Classification on Expert Level are separated from the standard User level and are collected in a different file, named L2A_CAL_SC_GIPP.xml. Whereas L2A_GIPP.xml is a pure user configuration file and thus is available for a standard user, the Expert level GIPPs are reserved for testing and calibration campaigns. Wrong calibrations might lead to heavy performance artefacts. The description of these parameters is thus postponed to Section 3.1 and standard users are warned to leave these calibration parameters untouched. For a full list of all GIPPs including their types, values and ranges, consult the embedded PDF in section 3.4.

2.2.3 Metadata

Quality Information data on Tile level are part of the Tile metadata as summarized in Figure 3. The Entries represent the percentage of classified pixels as listed for Table 2-10, related to the total amount of data pixels (100 %).

Quality Information data on User Product level are part of the User product Metadata. The structure follows the QI Data on tile level as displayed in Figure 3. Additional metadata are specified in Section 2.1.3 and Table 3-1.

2.2.4 Cython Library

In Sen2Cor 2.10, a new scene classification has been implemented. This requires a dedicated library (topographicshadows_cython_03) that is provided for each operating system.

2.2.5 Auxiliary Data

The ESACCI-LC for Sen2Cor data package is prepared for users of Sen2Cor version starting with sen2Cor 2.5.5 which want to benefit from the last improvements of Sen2Cor Cloud Screening and Classification module. This auxiliary data information is used in Sen2Cor to improve the accuracy of Sen2Cor classification over water, urban and bare areas and also to have a better handling of false detection of snow pixels.

Version 2.10:

For users of Sen2cor version 2.10, the updated tar file ESACCI-LC-L4-ALL-FOR-SEN2COR-2.10.tar is available for download from this location:

<https://earth.esa.int/eogateway/ftp/Sentinel-2/ESACCI-LC-L4-ALL-FOR-SEN2COR-2.10.tar.gz>

The updated tar file including the updated snow monthly climatology shall be extracted at the following location of Sen2cor installation: '\$SEN2COR_BIN/aux_data'.

It contains two files and one directory:

- ESACCI-LC-L4-LCCS-Map-300m-P1Y-2015-v2.0.7.tif
- ESACCI-LC-L4-WB-Map-150m-P13Y-2000-v4.0.tif
- *ESACCI-LC-L4-Snow-Cond-500m-MONTHLY-2000-2012-v2.4*

In L2A_CAL_SC_GIPP.xml, the reference to the Snow climatology has been updated with the replacement of the ESA CCI Snow Weekly Condition by a derived Snow Monthly climatology.

<ESACCI_SnowCondition_Map_Dir>ESACCI-LC-L4-Snow-Cond-500m-MONTHLY-2000-2012-v2.4</ESACCI_SnowCondition_Map_Dir>

Versions 2.5.5, 2.8, 2.9:

The original ESACCI-LC for Sen2Cor data package (ESACCI-LC-L4-ALL-FOR-SEN2COR.zip) is available for download from this location:

<http://maps.elie.ucl.ac.be/CCI/viewer/download.php>

This zip file shall then be extracted at this location of Sen2Cor installation:
'`$SEN2COR_BIN/aux_data/`' It contains two files and one directory:

- `ESACCI-LC-L4-LCCS-Map-300m-P1Y-2015-v2.0.7.tif`
- `ESACCI-LC-L4-WB-Map-150m-P13Y-2000-v4.0.tif`
- `ESACCI-LC-L4-Snow-Cond-500m-P13Y7D-2000-2012-v2.0`

Example on a Ubuntu (Linux) installation:

```
$ ls Sen2Cor-02.08.00-Linux64/lib/python2.7/site-packages/sen2cor/aux_data
ESACCI-LC-L4-LCCS-Map-300m-P1Y-2015-v2.0.7.tif
ESACCI-LC-L4-Snow-Cond-500m-P13Y7D-2000-2012-v2.0
ESACCI-LC-L4-WB-Map-150m-P13Y-2000-v4.0.tif
```

Example on a Windows 7 installation:

```
>dir Sen2Cor-02.08.00-Linux64/lib/python2.7/site-packages/sen2cor/aux_data
ESACCI-LC-L4-LCCS-Map-300m-P1Y-2015-v2.0.7.tif
ESACCI-LC-L4-Snow-Cond-500m-P13Y7D-2000-2012-v2.0
ESACCI-LC-L4-WB-Map-150m-P13Y-2000-v4.0.tif
```

Notes:

Note1: Please note that a Digital Elevation Model (DEM) is a pre-requisite for using ESACCI_LC information in the Scene Classification algorithm. In the case SRTM DEM is used, latitudes higher > 60 deg N (and lower < 60 deg S) are not covered by the SRTM DEM, therefore no ESACCI_LC information will be used for these latitudes. Standard Scene Classification algorithm will then be applied.

Note2: Please note that it is possible to use symbolic links in this aux_data folder if you prefer to copy those auxiliary files to another data folder. (unix command: `ln -s`, windows command: `mklink`)



Figure 3 – QI Data of Tile and User Product Metadata

2.2.6 Output Data













Table 2-8 – Cloud Probability map

Cloud Probability [QI Data]	
Unit	percentage
Range	0 - 100
Sampling	8 bit/sample
Resolution	60 m, 20 m

Table 2-9 – Snow Probability map

Snow Probability [QI Data]	
Unit	percentage
Range	0 – 100
Sampling	8 bit/sample
Resolution	60 m, 20 m

Table 2-10 – Scene Classification

Scene Classification [Image Data]		
Unit	enumeration	
Range	0	No Data (Missing data on projected tiles) (black) 
	1	Saturated or defective pixel (red) 
	2	Cast Shadows (very dark grey) 
	3	Cloud shadows (dark brown) 
	4	Vegetation (green) 
	5	Not vegetated (dark yellow) 
	6	Water (dark and bright) (blue) 
	7	Unclassified (dark grey) 
	8	Cloud medium probability (grey) 
	9	Cloud high probability (white) 
	10	Thin cirrus (very bright blue) 
	11	Snow or ice (very bright pink) 
Sampling	8 bit/sample	
Resolution	60 m, 20 m	

2.3 Atmospheric Correction

2.3.1 Input Data

L1C Image data as specified in Section 2.1.1, resampled to the requested resolution of 60, 20, 10 m. Scene Classification as specified in Section 2.2 resampled to the requested resolution of 60, 20, 10 m.

2.3.2 GIPP

Figure 4 shows the overall GIPP of the Atmospheric Correction Module. Table 2-11 reports the GIPP selection for the look-up tables.

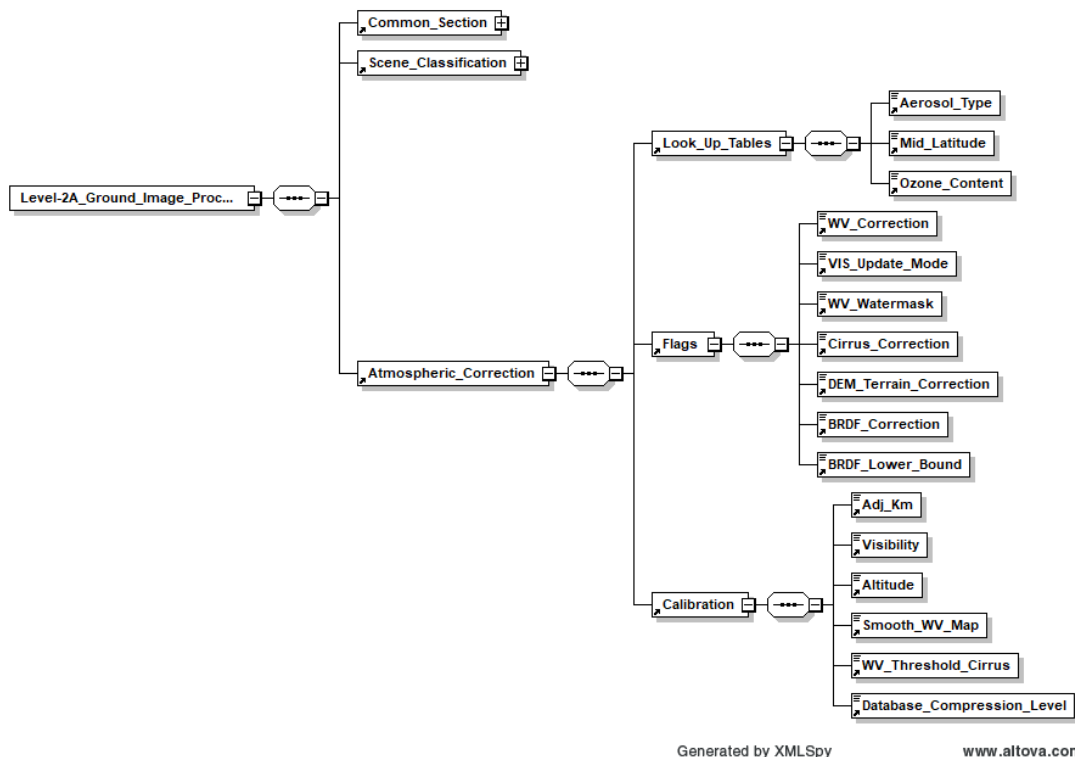

Figure 4 – GIPP for Atmospheric Correction Module

Table 2-11 – GIPP for selection of Look_Up_Tables

Field Name	Documentation	Type							
Aerosol_Type	The aerosol type used for atmospheric correction: a selection of AUTO will perform an automated aerosol type determination for this parameter as described in the SUM for Section 2.2.2.2.2. Default is: RURAL.	Choice: RURAL, MARITIME, AUTO							
Mid_Latitude	The mid latitude used for atmospheric correction a selection of AUTO will perform an automated aerosol type determination for this parameter as described in the SUM for Section 2.2.2.2.2. default is: SUMMER	Choice: SUMMER, WINTER, AUTO							
Ozone_Content, Summer	<p>The atmospheric temperature profile and ozone content for Mid_Latitude Summer Atmosphere.</p> <p>Default is: 0, which takes the best approximation from the ECMWFT metadata in the AUX_DATA folder of the input product. Otherwise the user can set the following numerical values:</p> <table border="1" data-bbox="699 1095 995 1480"> <thead> <tr> <th>Dobson Units</th> </tr> </thead> <tbody> <tr> <td>250</td> </tr> <tr> <td>290</td> </tr> <tr> <td>331 (standard MS)</td> </tr> <tr> <td>370</td> </tr> <tr> <td>410</td> </tr> <tr> <td>450</td> </tr> </tbody> </table>	Dobson Units	250	290	331 (standard MS)	370	410	450	Choice as given
Dobson Units									
250									
290									
331 (standard MS)									
370									
410									
450									

Field Name	Documentation	Type							
Ozone_Content, Winter	<p>The atmospheric temperature profile and ozone content for Mid_Latitude Summer Atmosphere.</p> <p>Default is 0, which takes the best approximation from the ECMWFT metadata in the AUX_DATA folder of the input product. Otherwise the user can set the following numerical values:</p> <table border="1" data-bbox="694 600 999 985"> <thead> <tr> <th>Dobson Units</th> </tr> </thead> <tbody> <tr><td>250</td></tr> <tr><td>290</td></tr> <tr><td>330</td></tr> <tr><td>377 (standard MW)</td></tr> <tr><td>420</td></tr> <tr><td>460</td></tr> </tbody> </table>	Dobson Units	250	290	330	377 (standard MW)	420	460	Choice as given
Dobson Units									
250									
290									
330									
377 (standard MW)									
420									
460									

For a full list of all types, parameters and default values, consult the embedded PDF in section 3.4.

2.3.2.1 Expert Level

GIPP for the Atmospheric Correction on Expert Level are separated from the standard User level and are collected in a different file, named L2A_CAL_AC_GIPP.xml. Whereas L2A_GIPP.xml is a pure user configuration file and thus is available for a standard user, the Expert level GIPPs are reserved for testing and calibration campaigns. Wrong calibrations might lead to heavy performance artefacts. The description of these parameters is thus postponed to Section 3.1 and standard users are warned to leave these calibration parameters untouched. For a full list of all GIPPs including their types, values and ranges, consult the embedded PDF in section 3.4.

2.3.3 Metadata

2.3.4 Auxiliary Data (Look Up Tables)

The algorithm for the atmospheric correction relies on a database of radiative transfer calculations using the DISORT 8-stream algorithm combined with the correlated k method. This has been converted to atmospheric LUTs based on the freely available LibRadtran library.

Table 2-12 – Parameter space for atmospheric correction

Parameter	Range	Increment / grid points
Solar zenith angle	0 -70°	10°
Sensor view angle	0 -10°	10°

Parameter	Range	Increment / grid points
Relative azimuth angle	0 -180°	30° (180°= backscatter)
Ground elevation	0 -2.5 km	0.5 km
Visibility	5 -120 km	5, 7, 10, 15, 23, 40, 80, 120 km
Water vapour, summer	0.4 -5.5 cm	0.4, 1.0, 2.0, 2.9, 4.0, 5.0 cm
Water vapour, winter	0.2 -1.5 cm	0.2, 0.4, 0.8, 1.1 cm

The baseline processing uses the mid-latitude summer (MS) atmospheric temperature / humidity profile with scaled water vapour columns of 0.4, 1.0, 2.0, 2.9, 4.0, and 5.0 cm (sea level geometry). A separate LUT file is used for each water vapour concentration. The baseline aerosol type is rural (continental). Calculations are performed for the ground elevations 0 – 2.5 km above sea level, in steps of 0.5 km. The default value of the ozone content is 331 DU (for sea level, decreasing with elevation). The water vapour dependent LUTs are used during the per-pixel water vapour retrieval for Sentinel-2 scenes.

The baseline LUTs are compiled for the rural aerosol and the mid-latitude summer (MS) atmosphere with its corresponding ozone column (331 DU for sea level). Other LUTs are selectable via configuration.

Water vapour columns are calculated using an equidistant 100 m grid.

LUT file name conventions: a name consists of 16 characters or numbers followed by the extension '.atm'. The first character defines the atmospheric temperature profile (h=summer, w=winter) and ozone content, followed by '99000' (indicating the symbolic satellite height of 99,000 m), followed by '_', then 'wvxy' where xy is the sea-level water vapour column, followed by '_' and a 4 letter aerosol identifier '_rura'.

Table 2-13 – LUT file naming conventions

Examples:	
h99000_wv29_rura.atm	MS atmosphere, water vapour=2.9 cm, rural, ozone=331 DU
w99000_wv11_rura.atm	MW atmosphere, water vapour=1.1 cm, rural, ozone=377 DU
Names for other aerosol types are coded with 4 letters, e.g.:	
h99000_wv29_mari.atm	MS, water vapour=2.9 cm, maritime, ozone=331 DU

Examples:	
h99000_wv29_urba.atm ¹	MS, water vapour=2.9 cm, urban, ozone=331 DU
h99000_wv29_dese.atm ¹	MS, water vapour=2.9 cm, desert, ozone=331 DU

The content are the following 6 radiative transfer functions for different atmospheric conditions, view angles 0° (nadir) and 10° off-nadir, and a range of solar geometries and relative azimuth angles.

Table 2-14 – Structure and format of the atmospheric LUT files

Column	Content
1. Lp	path radiance
2. Edf	diffuse flux at the sensor = (Tdir + Tdif)*Edif (where Edif is the diffuse solar flux at the ground)
3. Edr	direct (beam) irradiance at the sensor= (Tdir + Tdif) * Tsun * E Where: Tsun is the sun-to-ground direct transmittance, E = extra-terrestrial solar irradiance
4. Tdir	direct transmittance ground-to-sensor
5. Tdif	diffuse transmittance ground-to-sensor
6. s	spherical albedo of atmosphere

- The radiance, irradiance, and flux values are calculated for an earth-sun distance of 1 astronomical unit.
- Each LUT file stores the radiative transfer functions as float numbers in the binary platform independent XDR format.
- The Thuillier-2003 extra-terrestrial solar irradiance spectrum is used for the calculation of the LUTs (see Ref. Thuillier et al. 2003). It has been provided by ESA expressed in $\text{mW} \cdot \text{m}^{-2} \cdot \text{nm}^{-1}$ resampled at 1 nm.

LUTs are calculated for:

- ne = 6 elevations (0-2.5 km, increment 0.5 km),
- nz = 8 solar zenith angles (0-70°, increment 10°),
- nv = 8 visibilities (5, 7, 10, 15, 23, 40, 80, 120 km), and

¹ Currently not compiled

- nb bands: nb=12 for the 60 m data; nb=12 for the 20 m data; nb=4 for the 10 m data of Sentinel-2.

The sequence of data is arranged in a file with 104 columns and $nz \cdot nv \cdot nb$ lines:

Table 2-15 – Column structure of atmospheric LUT files

Column	Content
column 1	Solar zenith angle (first 0°, last 70°)
column 2	Visibility (first 5 km, last 120 km)
columns 3 – 8	Lp, Edf, Edr, Tdr, Tdf, s (nadir view), elevation=0 km
columns 9 – 19	Edf, Edr, Tdr, Tdf, Lp for 7 rel. azimuth angles 0(30)180°, at sensor view angle 10°, elevation = 0 km
columns 20 – 104	Columns 3 – 19 are repeated 5 times for the remaining elevations 0.5 to 2.5 km (increment 0.5 km)

Note: the spherical albedo s is the same for nadir and 10° off-nadir, therefore it is stored only once.

The contents of the file are written as a simple float binary array LUT=fltarr(2+17 * ne, nz, nv, nb) where the 17 radiative transfer functions are calculated for different parameter sets with ne (first=fastest loop = elevation), nz (second loop = solar zenith), nv (third loop = visibility) and nb (last loop = spectral band).

All Look Up Tables are located in two folders named lib_S2A and lib_S2B (for Sentinel 2A and/or Sentinel 2B satellite) in the sen2cor subdirectory and should never be changed or removed from a standard user, as they are essential for a proper atmospheric correction.

2.3.5 Output Data

Outputs are specified in the following subsections for the individual sub modules.

2.3.6 Aerosol Optical Thickness Retrieval

The aerosol optical thickness (τ) is defined as the integrated extinction coefficient over a vertical column of atmosphere of unit cross section. Extinction coefficient is the fractional depletion of radiance per unit path length (also called attenuation for radar frequencies). Example in formula:

$$I = I_0 (e^{-\tau})$$

If not enough Dense Dark Vegetation (DDV) pixels are available, Sen2Cor 2.10 switches to external sources. Starting with L1C Processing baseline (PB) 4.00, Total Aerosol Optical Thickness is provided as input in the L1C product in the Granule/Tile/Aux_data where the related Copernicus Atmosphere Monitoring Service (CAMS) file is present. Sen2Cor 2.10 retrieves from this file the *aerosol optical thickness* at 550 nm and the *geopotential* (z).

2.3.6.1 Input Data

Band subset as specified in Section 2.1.1, resampled to corresponding resolution of 60, 20, 10 m (see Table 15 – Band subsets).

Table 2-16 – Band subsets

CAMSxx	Purpose in L2A Processing context
B2 (490nm): 10 m	Sensitive to Vegetation Aerosol Scattering
B4 (665nm): 10 m	Max Chlorophyll absorption
B12 (2190nm): 20 m	AOT determination

Input retrieval in Sen2Cor 2.10.01 from the CAMS auxiliary file in case the number of DDV pixels is less than 1% (see Table 2-17).

Table 2-17 – CAMS auxiliary input

Variable and Raster Band number	Purpose in L2A processing context
AOD550	To retrieve the visibility map/index
Geopotential (z)	To retrieve the visibility map/index

2.3.6.2 GIPP

Figure 5– GIPP for selection of Look_Up_Tables, shows the GIPP of the Atmospheric Correction Module for the selection of the Look Tables (LUTs).

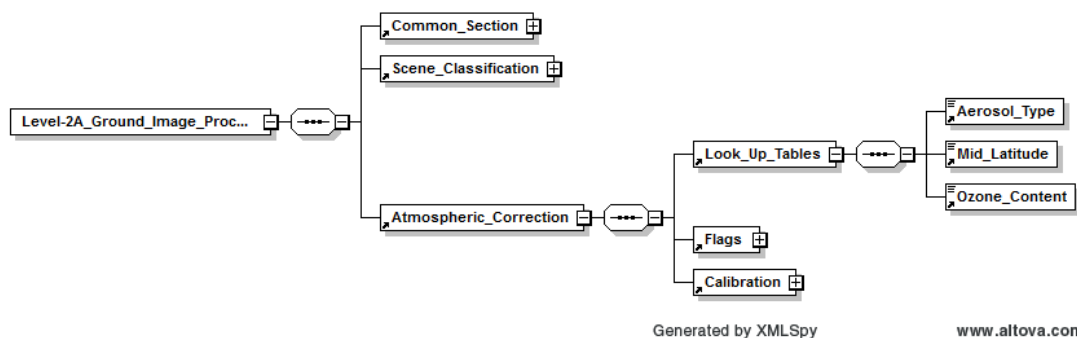

Figure 5– GIPP for selection of Look_Up_Tables

2.3.6.3 Metadata

Metadata are specified in Table 2-3.

2.3.6.4 Output Data

Table 2-18 – Aerosol Optical Thickness (AOT) map

Aerosol Optical Thickness (AOT) Map [Image Data]	
Unit	Unit less
Range	AOT = DN / 1000
Sampling	16 bit/pixel
Resolution	60 m, 20 m, 10 m (resampled from 20 m)

2.3.7 Water Vapour Retrieval

WV retrieval over land is performed with the Atmospheric Pre-corrected Differential Absorption algorithm (APDA) which is applied to the two Sentinel-2 bands B8A, and B9 (Fig. 4). Band 8A is the reference channel in an atmospheric window region. Band B9 is the measurement channel in the absorption region. The absorption depth is evaluated by calculating the radiance for an atmosphere with no WV, assuming that the surface reflectance for the measurement channel is the same as for the reference channel. The absorption depth is then a measure of the WV column content.

Typical ranges of water vapour columns are (sea-level-to space):

Table 2-19 – WVP columns

Conditions	WVP (cm)
tropical	3 - 5
midlatitude, summer	2 - 3
dry summer, spring, fall	1 - 1.5
dry desert or winter	0.3 - 0.8

2.3.7.1 Input Data

Band subsets are specified in Section 2.1.1, resampled to corresponding resolution of 60, 20 m.

Table 2-20 – Band subsets

Channels and Resolution	Purpose in L2A processing context
B8A (865nm): 20 m	Used for water vapour absorption (reference channel)

Channels and Resolution	Purpose in L2A processing context
B9 (945nm): 60 m	Water Vapour absorption atmospheric correction (measurement channel)

2.3.7.2 GIPP

Table 2-21 – GIPP input fields

Field Name	Documentation	Type
WV_Correction	0: no water vapour correction 1: water vapour correction using band B8A	Enumerator 0,1 as stated, default: 1
WV_Watermask	A choice to set the water vapour values for water pixels: 0 = not replaced, 1 = average water vapour value of land pixels is assigned to water pixels, 2 = line average of water vapour of land pixels is assigned to water pixels. Only available with WV_Correction mode 1	Enumerator 1,2, as stated 1: default 2: for future use, currently unused
Smooth_WV_Map	smooth water vapour map [m]	Floating point, 32 bit, default: 100 m

2.3.7.3 Metadata

None

2.3.7.4 Output Data

Table 2-22 – Water Vapour Map

Water Vapour Map [Image Data]	
Unit	Dimensionless
Range	0.3 – 5.5 cm
Sampling	16 bit
Resolution	60 m, 20 m, 10 m

2.3.8 Cirrus Correction

2.3.8.1 Input Data

Table 2-23 – Band subset

Channels and Resolution	Purpose in L2A processing context
B10 (1375): 60 m	Detection of thin cirrus for atmospheric correction

2.3.8.2 GIPP

Table 2-24 – Inputs parameter cirrus correction

Field Name	Documentation	Type
Cirrus_Correction	Flag for cirrus removal TRUE: enabled FALSE: disabled	Restricted string, TRUE / FALSE as stated
WV_Threshold_Cirrus	Water Vapour threshold to switch cirrus algorithm off [%]	Floating point value, 32 bit, default: 0.25

2.3.8.3 Metadata

None

2.3.8.4 Output Data

Contribution of cirrus correction to BOA surface reflectance for individual channels as listed in Section 2.3.10. The Cirrus band itself will be omitted in the Level 2A output, as it does not contain surface reflectance information and no direct user output.

2.3.9 Terrain Correction

2.3.9.1 Input Data

See metadata Section 2.3.9.3 below.

2.3.9.2 GIPP

Table 2-25 – GIPI terrain correction

Field Name	Documentation	Type
DEM_Directory	Directory where DEM will be expected (located under \$S2L2APPHOME). If set to 'false', no terrain correction will be performed. Example: 'dem/srtm'	Formatted string
DEM_Reference	Example: http://data_public:GDdci@data.cgiar-csi.org/srtm/tiles/GeoTIFF/	Formatted string
DEM_Terrain_Correction	Boolean Flag for using DEM for terrain correction. Otherwise only used for scene classification and AOT	Formatted string
Altitude	Assumed altitude if no DEM is present [km]	Floating point value, 32 bit, default: 0.10, equals 100 m
BRDF_Correction	<p>Empirical BRDF correction with factor (G) according to following equation:</p> $G = \{ \cos(\beta_i) / \cos(\beta_T) \}^b \geq g \quad (\text{eq. 1})$ <p>where:</p> <p>β_i: local solar zenith angle (from metadata, Section 1.1.3).</p> <p>β_T: threshold for surface reflectance (determined programmatically).</p> <p>b: exponent, set via options below.</p> <p>g: Lower boundary of BRDF correction factor, recommended between 0.2 and 0.25 (see next parameter, below).</p> <p><u>Options to be selected (Exponent b):</u></p> <p>0: no empirical BRDF correction (or flat terrain)</p> <p>1: correction with cosine of local solar zenith angle (eq. 1 with b=1)</p> <p>2: correction with sqrt(cos) of local solar zenith angle (eq. 1 with b=1/2 correction).</p>	Enumerator 0, 1, 2
BRDF_Lower_Bound	Lower boundary of BRDF correction factor, should be between 0.2 and 0.25.	Float, default 0.22

2.3.9.3 Metadata

- DEM (as specified in the GIPP, will be internally prepared and adapted to geo-positional coordinates obtained from the JPEG-2000 image headers)
- Terrain Shadow Map (calculated internally via GDAL)
- Slope Map (calculated internally via GDAL)
- Aspect Map (calculated internally via GDAL)

2.3.9.4 Output Data

Corrections of BOA surface reflectance retrieval for bands B01 – B12, except B10) as listed in Section 2.3.10. No separate user output.

2.3.10 Surface Reflectance

2.3.10.1 Input Data

60, 20 m Resolution

- Full set of Bands as specified in Section 2.1.1, Table 2-1, (except Band 8) resampled to corresponding resolution;
- Aerosol Map as specified in Table 2-18;
- Water Vapour Map as specified in Table 2-22;
- (Optional) Cirrus correction as specified in Section 2.3.8.4;
- (Optional) Terrain correction as specified in Section 2.3.9.4.

10 m Resolution

- Bands 2,3,4,8 as specified in Section 2.1.1, Table 1, no resampling;
- Resampled Aerosol Map as specified in Table 2-18;
- Water Vapour Map as specified in Table 2-22;
- (Optional) Terrain correction as specified in Section 2.3.9.4

2.3.10.2 GIPP

Table 2-26 – GIPP surface reflectance

Field Name	Documentation	Type
Adj_Km	Range of adjacency effect (reflected radiation from neighbourhood) in [km]	Floating point, 32 bit, Default: 1.0

2.3.10.3 Metadata

None

2.3.10.4 Output Data

Table 2-27 – Outputs surface reflectance

Name	Level-2A
Product	L2A, BOA Reflectance
Coverage	Regional
Packaging	Tiles (same area coverage as Level 1C input data)
Geo-location accuracy	Identical to the level 1C geo-location performance.
Frequency	Variable upon Level 1C products availability.
Format	<p>OpenJPEG 2.1.2 details @60 m processing:</p> <p>Codestream, export Band 1, res 60m: SOC marker segment @ (1866, 0) SIZ marker segment @ (1868, 41) Profile: no profile Reference Grid Height, Width: (1830 x 1830) Vertical, Horizontal Reference Grid Offset: (0 x 0) Reference Tile Height, Width: (192 x 192) Vertical, Horizontal Reference Tile Offset: (0 x 0) Bitdepth: (16,) Signed: (False,) Vertical, Horizontal Subsampling: ((1, 1),) COD marker segment @ (1911, 18) Coding style: Entropy coder, with partitions SOP marker segments: False EPH marker segments: False Coding style parameters: Progression order: LRCP Number of layers: 1 Multiple component transformation usage: no transform specified Number of resolutions: 6 Code block height, width: (4 x 4) Wavelet transform: 5-3 reversible Precinct size: ((64, 64), (64, 64), (64, 64), (64, 64), (64, 64), (64, 64)) Code block context: Selective arithmetic coding bypass: False Reset context probabilities on coding pass boundaries: False Termination on each coding pass: False Vertically stripe causal context: False Predictable termination: False Segmentation symbols: False QCD marker segment @ (1931, 19) Quantization style: no quantization, 2 guard bits Step size: [(0, 16), (0, 17), (0, 17), (0, 18), (0, 17), (0, 17), (0, 18), (0, 17), (0, 17), (0, 18), (0, 17), (0, 17), (0, 18), (0, 17), (0, 17), (0, 18), (0, 17), (0, 17), (0, 18)] CME marker segment @ (1952, 37)</p>
Unit	Dimensionless, Unsigned Integer

Name	Level-2A
Calibration and Range	1 / 10.000: i.e.: Digital Numbers 0 : 10.000, representing radiometric reflectance values from 0.0 to 1.0
Sampling	16 bits / pixel
Input resolution	Generated output resolution
B1 (443nm): 60 m	60 m, 20 m (Sen2Cor 2.10)
B2 (490nm): 10 m	60 m, 20 m, 10 m
B3 (560nm): 10 m	60 m, 20 m, 10 m
B4 (665nm): 10 m	60 m, 20 m, 10 m
B5 (705nm): 20 m	60 m, 20 m
B6 (740nm): 20 m	60 m, 20 m
B7 (783nm): 20 m	60 m, 20 m
B8 (842nm): 10 m	10 m
B8a (865nm): 20 m	60 m, 20 m
B9 (945nm): 60 m	60 m
B10 (1375): 60 m	No output generated as it does not contain surface information

Name	Level-2A
B11 (1610nm): 20 m	60 m, 20 m
B12 (2190nm): 20 m	60 m, 20 m

2.4 Quality Mask

From version 2.10 Sen2Cor supports and handles L1C quality masks in raster format describing invalid pixels in the L1C input data.

2.4.1 Input Data

L1C_product/GRANULE/tile_id/QI_DATA/ contains MSK_QUALIT_BXX.jp2 (where XX is the number of the bands). The files with the affected bands are open and a mask is created.

2.4.2 GIPP

The L2A_GIPP.xml configuration file contains a new parameter: 'Handle_L1C_QLT_Mask' that has to be set to 'TRUE' if the user wants to use the Quality Mask.

2.4.3 Metadata

Sen2Cor reads from the file GENERAL_QUALITY.xml (present in the folder L1C_product/GRANULE/tile_id/QI_DATA/) if loss of data is reported. In the affirmative case, it reads the list of the affected bands. Below, an example of a <check> from a GENERAL_QUALITY.xml reporting data loss and affected bands.

```
<check>
  <inspection creation="2018-01-19T21:58:24.747Z" duration="276"
  execution="2018-01-19T21:58:24.762Z" id="Data_Loss"
  item="S2B_OPER_MSI_L1C_TL_MTI__20180119T211945_A004558_T07LEK_N02.06"
  itemURL="/dpc/data/phoebus-share/PHOEBUS-
  3.4.1/wp_in_progress/l1c_20180119_17/app_data/steps_data/L1C/TILE/S2B_OPER_M
  SI_L1C_TL_MTI__20180119T211945_A004558_T07LEK_N02.06/" name="Check TECQUA
  for data loss " priority="5" processingStatus="done" status="FAILED"/>
  <message contentType="text/plain">There is data loss in this tile.</message>
  <extraValues>
  <value name="Affected Bands">B06 B07 B08 B09 B10 B11 B8A</value>
  </extraValues>
</check>
```

2.4.4 Output Data

The generated mask will be visible in the L2A *.jp2 output (for example the *_TCI_*.jp2 file).

2.5 Product Generation

2.5.1 Input Data

All outputs from previous sections.

2.5.2 Output Data

The generated output is dependent on the command line input as shown below. The output products itself are described and specified in detail in [S2-PDGS-MPC-L2A-PFS] and thus not repeated here.

2.5.2.1 Datastrip Generation

Command Line Parameter:

```
L2A_Process --mode=generate_datastrip --datastrip=L1C_DATASTRIP
  --output_dir=L2A_OUTPUT_DIR --work_dir=WORK_DIR --processing_centre=PROCESSING_CENTRE
  --archiving_centre=ARCHIVING_CENTRE --GIP_L2A_PB=GIP_L2A_PB (optional)
  --resolution=RESOLUTION (optional)
```

Generates a datastrip with optional processing baseline settings, which can be used as input for the next step of processing a single tile.

Input product should be in SAFE standard format. Output product will have the datastrip directory in SAFE standard format as well, all other components like metadata and reports will be generated in SAFE compact format.

2.5.2.2 Tile Generation

Command Line Parameter:

```
L2A_Process --mode=process_tile --datastrip=L2A_DATASTRIP --tile=L1C_TILE
  --output_dir=L2A_OUTPUT_DIR --work_dir=WORK_DIR --GIP_L2A_PB=GIP_L2A_PB (optional)
  --resolution=RESOLUTION (optional) --img_database_dir=IMG_DATABASE_DIR (optional)
  --res_database_dir=RES_DATABASE_DIR (optional)
```

Processes a tile with optional database locations and optional processing baseline settings, using a generated L2A datastrip as input. Database directories have been split into two different entities, one for the L1C image inputs, which will be kept in read only mode and a second database for the resampled auxiliary and intermediate products, which always will be overwritten and removed during the successive processing steps.

Input product should be in SAFE standard format. Output product will have the tile directory in SAFE standard format as well, all other components like metadata images and reports will be generated in SAFE compact format.

2.5.2.3 EUP Generation (Toolbox Mode)

Command Line Parameter:

```
L2A_Process input
usage: L2A_Process L1C_USER_PRODUCT --GIP_L2A_PB=GIP_L2A_PB (optional)
  --resolution=RESOLUTION (optional)
```

Processes an End User Product with optional processing baseline settings, using an L1C End User product of PSD Version 14.3 as input.

Input product should be V.14.3 SAFE compact format. Output product will also be generated in SAFE compact format. Older products below PSD 14.3 will no longer be supported.

2.5.2.4 Additional Output (Sen2cor 2.10, PSD >= 14.9)

Since Sen2cor 2.10 (PSD >= 14.9) additional output comprises:

1- Additional L2A Quality parameters have been added to the already existing parameter in the L2A tile metadata in the 'Quality_Indicator_Info' section. These include:

- a. Cloudy_pixel_over_land_percentage;
- b. AOT_retrieval_method;
- c. Granule_mean_AOT;
- d. Granule_mean_wv;
- e. Ozone_Source;
- f. Ozone_Value.

2- Provision of the L2A Quality Report (see Figure 6): the new L2A_Quality.xml report provides quality indicators information derived during the L2A process. They are separated in three main groups (that are subsequently divided into several subsections):

- g. Scene Class Quality Indicators;
- h. Atmospheric Correction Quality Indicators;
- i. Auxiliary Data Quality indicators.

A detailed description can be found at the end of the document in section 3.4.

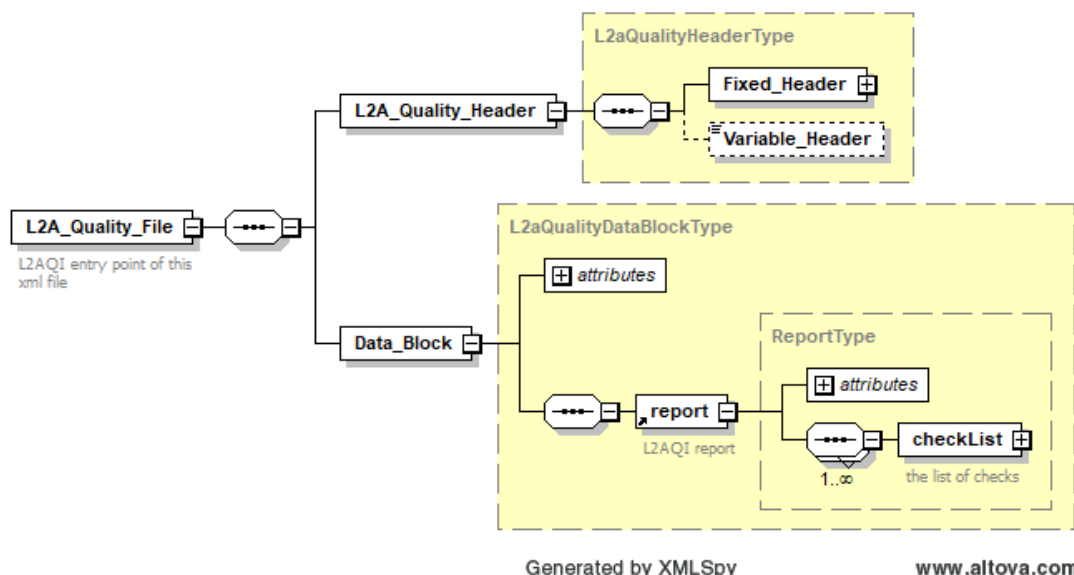

Figure 6: General schema of the new L2A_Quality file

Below an example of a L2A_Quality file:

```
<?xml version="1.0" encoding="UTF-8"?>

-<L2A_Quality_File xsi:schemaLocation="http://gs2.esa.int/DATA_STRUCTURE/I2aqiReport
L2A_QUALITY.xsd" xmlns="http://gs2.esa.int/DATA_STRUCTURE/I2aqiReport"
xmlns:xsi="http://www.w3.org/2001/XMLSchema-instance">
-<L2A_Quality_Header>
-<Fixed_Header>
<File_Name>L2A_QUALITY</File_Name>
<File_Description>Quality information obtained from Sen2Cor</File_Description>
<Notes/>
<Mission>S2B</Mission>
<!-- This can be set to OPER or USER dependent on PDGS or Toolbox mode -->
<File_Class>OPER</File_Class>
<File_Type>L2A_QLINFO</File_Type>
-<Validity_Period>
<Validity_Start>UTC=2015-06-22T00:00:00</Validity_Start>
<Validity_Stop>UTC=2100-01-01T00:00:00</Validity_Stop>
</Validity_Period>
<File_Version>1</File_Version>
-<Source>
<System>Sen2Cor</System>
<Creator>Sen2Cor</Creator>
<Creator_Version>2.10</Creator_Version>
<Creation_Date>UTC=2021-10-12T08:13:50</Creation_Date>
</Source>
</Fixed_Header>
</L2A_Quality_Header>
-<Data_Block type="xml">
-<report date="2021-10-12T00:00:00Z" globalStatus="PASSED" gippVersion="2.10.0">
-<checkList>
<parentID>L2A_SC</parentID>
<name>SCENE_CLASS_QUALITY</name>
<version>2.10</version>
<item
url="/Users/Shared/Testdata/FCP_TEST/45RVP/TL/input/S2B_OPER_MSI_L1C_TL_VGSR_20211004T
094631_A021913_T30QVE_N79.90/GRANULE/S2B_OPER_MSI_L2A_TL_VGSR_20211004T113819_A
021913_T30QVE_N79.90/AUX_DATA"
name="S2B_OPER_MSI_L2A_TL_VGSR_20211004T113819_A021913_T30QVE_N79.90"
className="PDI Level 2A Tile Folder" class="http://www.esa.int/s2#pdi_level_2a_tile_container"/>
-<check>
<message contentType="text/plain">"Percentage of classified pixels"</message>
-<extraValues>
<value name="CLOUDY_PIXEL_PERCENTAGE">1.970349</value>
<value name="CLOUDY_PIXEL_OVER_LAND_PERCENTAGE">1.970349</value>
<value name="DEGRADED_MSI_DATA_PERCENTAGE">0.023900</value>
<value name="NODATA_PIXEL_PERCENTAGE">0.000000</value>
<value name="SATURATED_DEFECTIVE_PIXEL_PERCENTAGE">0.000000</value>
<value name="DARK_FEATURES_PERCENTAGE">0.000000</value>
<value name="CLOUD_SHADOW_PERCENTAGE">0.000000</value>
<value name="VEGETATION_PERCENTAGE">0.000000</value>
<value name="NOT_VEGETATED_PERCENTAGE">98.029649</value>
<value name="WATER_PERCENTAGE">0.000000</value>
<value name="UNCLASSIFIED_PERCENTAGE">0.000000</value>
<value name="MEDIUM_PROBA_CLOUDS_PERCENTAGE">0.000000</value>
<value name="HIGH_PROBA_CLOUDS_PERCENTAGE">0.000000</value>
<value name="THIN_CIRRUS_PERCENTAGE">1.970349</value>
<value name="SNOW_ICE_PERCENTAGE">0.000000</value>
</extraValues>
</check>
</checkList>
-<checkList>
<parentID>L2A_AC</parentID>
```

```

<name>ATMOSPHERIC_CORRECTION_QUALITY</name>
<version>2.10</version>
<item
url="/Users/Shared/Testdata/FCP_TEST/45RVP/TL/input/S2B_OPER_MSI_L1C_TL_VGSR_20211004T
094631_A021913_T30QVE_N79.90/GRANULE/S2B_OPER_MSI_L2A_TL_VGSR_20211004T113819_A
021913_T30QVE_N79.90/AUX_DATA"
name="S2B_OPER_MSI_L2A_TL_VGSR_20211004T113819_A021913_T30QVE_N79.90"
className="PDI Level 2A Tile Folder" class="http://www.esa.int/s2#pdi_level_2a_tile_container"/>
-<check>
<message contentType="text/plain">Atmospheric correction quality values</message>
-<extraValues>
<value name="AOT_RETRIEVAL_ACCURACY">0.000000</value>
<value name="GRANULE_MEAN_AOT">0.407783</value>
<value name="WV_RETRIEVAL_ACCURACY">0.000000</value>
<value name="GRANULE_MEAN_WV">2.194568</value>
<value name="OZONE_VALUE">261.249328</value>
<value name="START_VISIBILITY_KM">40.000000</value>
<value name="VISIBILITY_FROM_DDV_KM">40.000000</value>
<value name="FINAL_VISIBILITY_KM">16.620000</value>
<value name="AVERAGE_SOLAR_ZENITH_ANGLE">17.590239</value>
<value name="DDV_PIXEL_PERCENTAGE">0.000000</value>
<value name="DDV_REFLECTANCE_RANGE">0.000000</value>
<value name="BLUE_PATH_RADIANCE_RESCALING_FACTOR">1.000000</value>
</extraValues>
</check>
-<check>
<message contentType="text/plain">Atmospheric correction quality control</message>
-<extraValues>
<!-- WV_RETRIEVAL_METHOD: SEN2COR_APDA -->
<value name="WV_RETRIEVAL_METHOD">SEN2COR_APDA</value>
<!-- AOT_RETRIEVAL_METHOD: SEN2COR_DDV | CAMS | DEFAULT -->
<value name="AOT_RETRIEVAL_METHOD">CAMS</value>
<value name="VISIBILITY_LESS_THAN_5_KM">False</value>
<value name="AOT_ABOVE_1">False</value>
<value name="GRANULE_WV_ABOVE_5_CM">False</value>
</extraValues>
</check>
-<check>
<message contentType="text/plain">Percentage of negative BOA pixels</message>
-<extraValues>
<value name="B01">0.000000</value>
<value name="B02">0.000000</value>
<value name="B03">0.000000</value>
<value name="B04">0.000000</value>
<value name="B06">0.000000</value>
<value name="B07">0.000000</value>
<value name="B08">0.000000</value>
<value name="B8A">0.000000</value>
<value name="B11">0.000000</value>
<value name="B12">0.000000</value>
</extraValues>
</check>
-<check>
<message contentType="text/plain">Look up table file list</message>
-<extraValues>
<value name="LUT_DATA_FILES">['f99000_wv20_rura.atm']</value>
</extraValues>
</check>
</checkList>
-<checkList>
<parentID>L2A_AUX</parentID>
<name>AUX_DATA_QUALITY</name>
<version>2.10</version>
<item
url="/Users/Shared/Testdata/FCP_TEST/45RVP/TL/input/S2B_OPER_MSI_L1C_TL_VGSR_20211004T

```

```

094631_A021913_T30QVE_N79.90/GRANULE/S2B_OPER_MSI_L2A_TL_VGSR_20211004T113819_A
021913_T30QVE_N79.90/AUX_DATA"
name="S2B_OPER_MSI_L2A_TL_VGSR_20211004T113819_A021913_T30QVE_N79.90"
className="PDI Level 2A Tile Folder" class="http://www.esa.int/s2#pdi_level_2a_tile_container"/>
-<check>
<message contentType="text/plain">AUX related parameters</message>
-<extraValues>
<!-- DEM_TYPE: SRTM_90 | DTED_90 | COPERNICUS_90 -->
<value name="DEM_TYPE">SRTM_90</value>
<value name="DEM_MEAN_ALTITUDE_KM">0.278077</value>
<value name="DEM_MEAN_SLOPE">1.1955457</value>
<value name="GROUND_ELEVATION_ABOVE_3_KM">False</value>
<value name="SOLAR_ZENITH_ANGLE_ABOVE_70_DEG">False</value>
<!-- OZONE_SOURCE: AUX_ECMWFT | CONFIG | OTHER -->
<value name="OZONE_SOURCE">AUX_ECMWFT</value>
</extraValues>
</check>
-<check>
<message contentType="text/plain">AUX data file list</message>
-<extraValues>
<value name="AUX_DATA_FILES">['srtm_36_09.tif']</value>
</extraValues>
</check>
</checkList>
</report>
</Data_Block>
</L2A_Quality_File>
  
```

3. GIPP Additional Settings

3.1 Expert Parameters for Scene Classification

The default expert parameters for the Scene Classification are located in a file named L2A_CAL_SC_GIPP.xml, located in the cfg folder of the sen2cor subdirectory within the Sen2Cor package. They can be overwritten with an external configuration referred to via command line (see section 2.1.7).

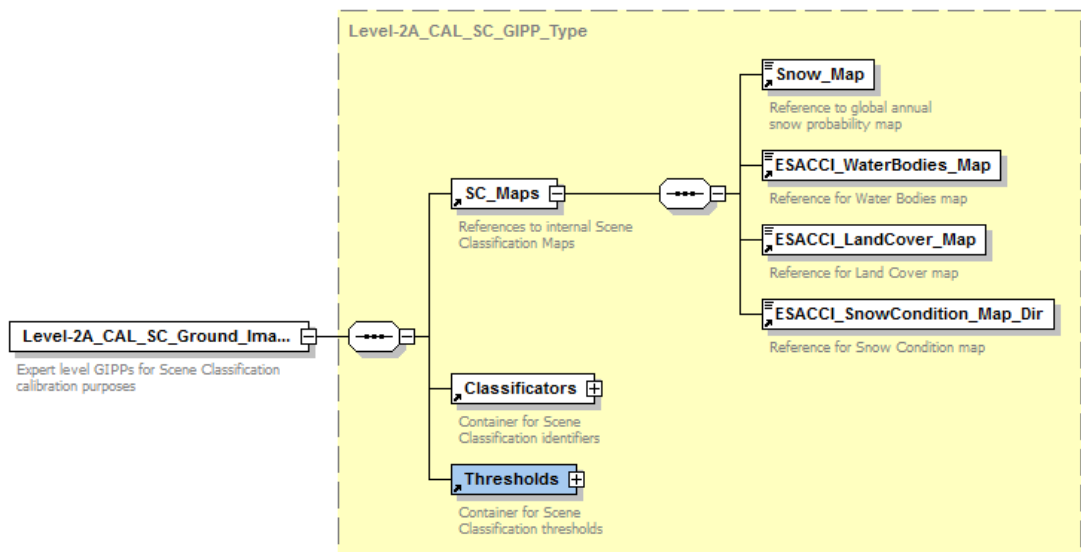

Figure 7 – Processing Baseline GIPP

For a full list of all types, parameters and default values, consult the embedded PDF in section 3.4.

3.2 Expert Parameters for Atmospheric Correction

The default expert parameters for the Atmospheric Correction are located in a file named L2A_CAL_AC_GIPP.xml, located in the cfg folder of the sen2cor subdirectory within the Sen2Cor package. They can be overwritten with an external configuration referred to via command line (see section 2.1.7).

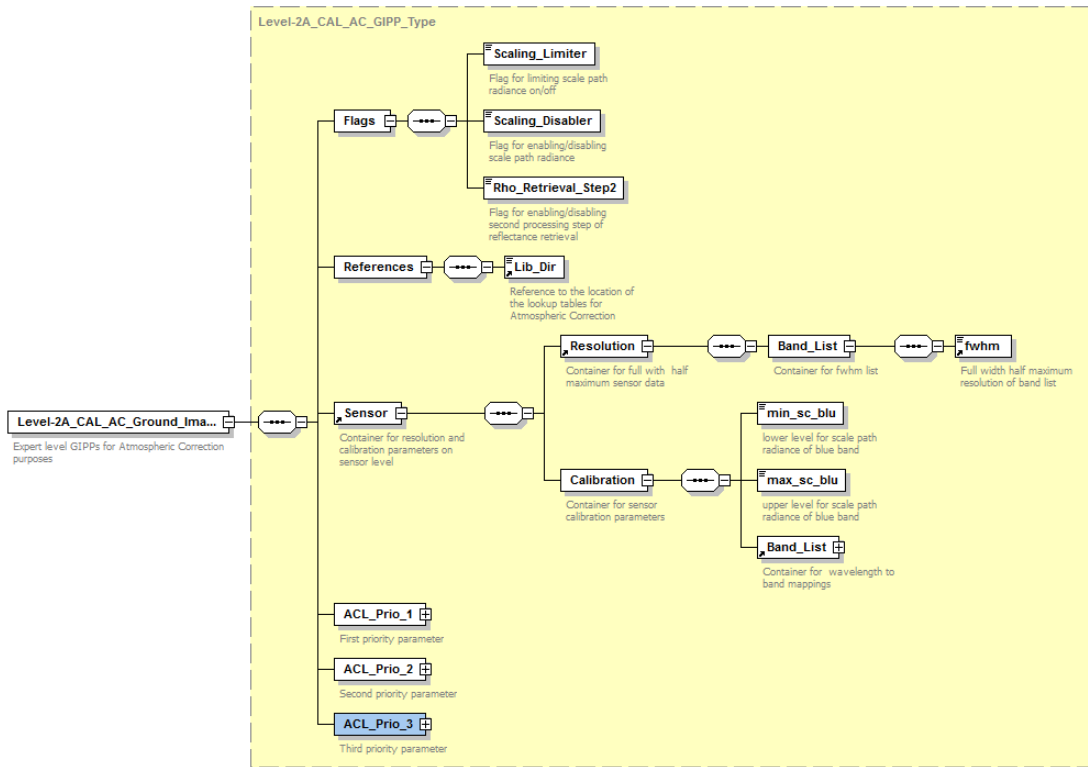

Figure 8 – Processing Baseline GIPP

For a full list of all types, parameters and default values, consult the embedded GIPP PDF in Section 3.4.

3.3 Processing Baseline Parameters

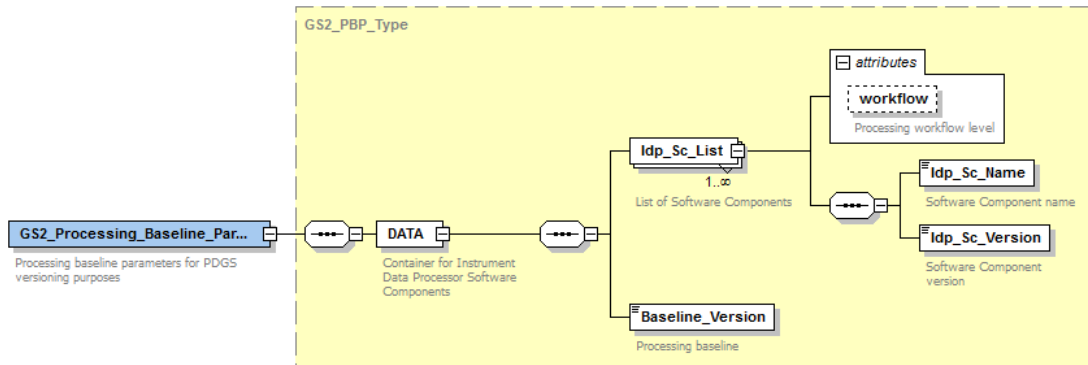

Figure 9 – Processing Baseline GIPP

Table 3-1 – Processing Baseline GIPP

Field Name / Attribute	Documentation	Type
DATA	Container for Instrument Data Processor Software Components	Complex
IDp_Sc_List	List of Software Components	Complex
workflow	Processing workflow level	String
IDp_Sc_Name	Software Component name	String
IDp_Sc_Version	Software Component version	String
Baseline_Version	Processing baseline	Double

Adding an optional xml input in the format of a processing baseline allows overwriting the corresponding fields in the metadata and filenames.

For a full list of all types, parameters and default values, consult the embedded PDF in section 3.4.

3.4 Additional Documentation

The full reference of all GIPP is contained in the embedded PDF document:



Sen2Cor_2_10_0_L2
A_GIPP.pdf